



**PART A  
INVITATION TO BID**

<b>THE SUCCESSFUL BIDDER WILL BE REQUIRED TO FILL IN AND SIGN A WRITTEN CONTRACT FORM (WBD7).</b>					
BID NUMBER:	WCNCB 03/05/2025	CLOSING DATE:	18/06/2025	CLOSING TIME:	11H00 AM
DESCRIPTION	Repairs to the Pontoon at Goukamma Nature Reserve.				

BID RESPONSE DOCUMENTS MAY BE DEPOSITED IN THE BID BOX SITUATED AT CAPENATURE HEAD OFFICE

<p><b>CapeNature Head Office</b>  <b>PGWC Shared Services Centre</b>          3<sup>rd</sup> Floor          Cnr Bosduif &amp; Volstruis Streets          Bridgetown          7764</p>	<p><b>Please note that a compulsory briefing session will be held on Wednesday 28 May 2025 at 10:00 AM, at Goukamma Nature Reserve.</b></p> <p><b>Goukamma Nature Reserve is situated between Sedgefield and Knysna 5 Kilometres along the Buffalo Bay Road.</b></p> <p><b>GPS: 34°4'6.73"S 22°56'52.29"E</b></p>
<p><b>Tender's Email Address (For submission of bid documents only):</b></p> <p><a href="mailto:tenders@capenature.co.za">tenders@capenature.co.za</a></p>	

SUPPLIER INFORMATION					
NAME OF BIDDER					
POSTAL ADDRESS					
STREET ADDRESS					
TELEPHONE NUMBER	CODE		NUMBER		
CELLPHONE NUMBER					
FACSIMILE NUMBER	CODE		NUMBER		
E-MAIL ADDRESS					
VAT REGISTRATION NUMBER					
	WCSD REGISTRATION No.		<b>AND</b>	CSD No:	

B-BBEE STATUS LEVEL VERIFICATION CERTIFICATE [TICK APPLICABLE BOX]	<input type="checkbox"/> Yes  <input type="checkbox"/> No	B-BBEE STATUS LEVEL SWORN AFFIDAVIT	<input type="checkbox"/> Yes  <input type="checkbox"/> No
IF YES, WHO WAS THE CERTIFICATE ISSUED BY?	<input type="checkbox"/>	A VERIFICATION AGENCY ACCREDITED BY THE SOUTH AFRICAN ACCREDITATION SYSTEM (SANAS)	
	<input type="checkbox"/>	A REGISTERED AUDITOR	

**[A B-BBEE STATUS LEVEL VERIFICATION CERTIFICATE/SWORN AFFIDAVIT (FOR EMEs& QSEs) MUST BE SUBMITTED TOGETHER WITH A COMPLETED 6.1 IN ORDER TO QUALIFY FOR PREFERENCE POINTS FOR B-BBEE]**

ARE YOU THE ACCREDITED REPRESENTATIVE IN SOUTH AFRICA FOR THE GOODS /SERVICES /WORKS OFFERED? [IF YES ENCLOSE PROOF]	<input type="checkbox"/> Yes <input type="checkbox"/> No	ARE YOU A FOREIGN BASED SUPPLIER FOR THE GOODS /SERVICES /WORKS OFFERED?	<input type="checkbox"/> Yes <input type="checkbox"/> No [IF YES ANSWER PART B:3 BELOW]
SIGNATURE OF BIDDER .....		DATE	
CAPACITY UNDER WHICH THIS BID IS SIGNED (Attach proof of authority to sign this bid; e.g. resolution of directors, etc.)			
TOTAL NUMBER OF ITEMS OFFERED		TOTAL BID PRICE (ALL INCLUSIVE)	
<b>BIDDING PROCEDURE ENQUIRIES MAY BE DIRECTED TO:</b>		<b>TECHNICAL INFORMATION MAY BE DIRECTED TO:</b>	
DEPARTMENT/ PUBLIC ENTITY	CapeNature	CONTACT PERSON	Barend Le Roux
CONTACT PERSON	Imran Brey	TELEPHONE NUMBER	087 087 3061
TELEPHONE NUMBER	087 087 4103	FACSIMILE NUMBER	N/A
FACSIMILE NUMBER	NA	E-MAIL ADDRESS	<a href="mailto:bleroux@capenature.co.za">bleroux@capenature.co.za</a>
E-MAIL ADDRESS	<a href="mailto:ibrey@capenature.co.za">ibrey@capenature.co.za</a>		

**PART B  
TERMS AND CONDITIONS FOR BIDDING**

**1. BID SUBMISSION:**

- 1.1. BIDS MUST BE DELIVERED BY THE STIPULATED TIME TO THE CORRECT ADDRESS. LATE BIDS WILL NOT BE ACCEPTED FOR CONSIDERATION.
- 1.2. ALL BIDS MUST BE SUBMITTED ON THE OFFICIAL FORMS PROVIDED--(NOT TO BE RE-TYPED)
- 1.3. BIDDERS MUST REGISTER ON THE CENTRAL SUPPLIER DATABASE (CSD) TO UPLOAD MANDATORY INFORMATION NAMELY: (BUSINESS REGISTRATION/ DIRECTORSHIP/ MEMBERSHIP/IDENTITY NUMBERS; TAX COMPLIANCE STATUS; AND BANKING INFORMATION FOR VERIFICATION PURPOSES). B-BBEE CERTIFICATE OR SWORN AFFIDAVIT FOR B-BBEE MUST BE SUBMITTED TO BIDDING INSTITUTION.
- 1.4. THIS BID IS SUBJECT TO THE PREFERENTIAL PROCUREMENT POLICY FRAMEWORK ACT 2000 AND THE PREFERENTIAL PROCUREMENT REGULATIONS, 2017, THE GENERAL CONDITIONS OF CONTRACT (GCC) AND, IF APPLICABLE, ANY OTHER LEGISLATION OR SPECIAL CONDITIONS OF CONTRACT.

**2. TAX COMPLIANCE REQUIREMENTS**

- 2.1 BIDDERS MUST ENSURE COMPLIANCE WITH THEIR TAX OBLIGATIONS.
- 2.2 APPLICATION FOR TAX COMPLIANCE STATUS (TCS) MAY ALSO BE MADE VIA E-FILING. IN ORDER TO USE THIS PROVISION, TAXPAYERS WILL NEED TO REGISTER WITH SARS AS E-FILE USER THROUGH THE WEBSITE WWW.SARS.GOV.ZA.
- 2.3 BIDDERS MAY ALSO SUBMIT A PRINTED TCS WITH A RESULT SUMMARY PAGE (DOWNLOADED FROM EFILING) TOGETHER WITH THE BID.
- 2.4 IN BIDS WHERE CONSORTIA / JOINT VENTURES / SUB-CONTRACTORS ARE INVOLVED, EACH PARTY MUST SUBMIT A SEPARATE PROOF OF TCS AS MENTIONED IN 2.3 ABOVE.

**3. QUESTIONNAIRE TO BIDDING FOREIGN SUPPLIERS**

- 3.1. IS THE BIDDER A RESIDENT OF THE REPUBLIC OF SOUTH AFRICA (RSA)?  YES  NO
- 3.2. DOES THE BIDDER HAVE A BRANCH IN THE RSA?  YES  NO
- 3.3. DOES THE BIDDER HAVE A PERMANENT ESTABLISHMENT IN THE RSA?  YES  NO
- 3.4. DOES THE BIDDER HAVE ANY SOURCE OF INCOME IN THE RSA?  YES  NO

**IF THE ANSWER IS "NO" TO ALL OF THE ABOVE, THEN, IT IS NOT A REQUIREMENT TO PROVIDE PROOF OF TAX COMPLIANCE STATUS; NOR OBTAIN A TAX COMPLIANCE STATUS FROM THE SOUTH AFRICAN REVENUE SERVICE (SARS) IF NOT REGISTER AS PER 2.2 ABOVE.**

**\*FAILURE TO PROVIDE ANY OF THE ABOVE PARTICULARS MAY RENDER THE BID INVALID.**

SIGNATURE OF BIDDER: .....

CAPACITY UNDER WHICH THIS BID IS SIGNED: .....

(Proof of authority must submitted e.g. company resolution)

DATE: .....

## TAX CLEARANCE REQUIREMENTS

### IT IS A CONDITION OF THE TENDER THAT -

1. The taxes of the successful service provider **must** be in order, or that satisfactory arrangements have been made with the Receiver of Revenue to meet his / her tax obligations.
2. Application for tax clearance must be done through the Receiver of Revenue office where the service provider is registered for tax purposes. The Receiver of Revenue will then furnish the Supplier with a Tax Clearance Certificate that will be valid for a period of one year from date of issue.
3. This Tax Clearance Certificate must be submitted in the original together with the tender. Failure to submit the **original** and valid Tax Clearance Certificate **will** invalidate the tender. If a tax clearance certificate was submitted previously to CapeNature please indicate as such.
4. In quotations where Consortia / Joint Ventures / Sub-contractors are involved each party must submit a separate Tax Clearance Certificate. Copies of the Application for Tax Clearance Certificates are available at any Receiver's Office.

<b>HAS A TAX CLEARANCE CERTIFICATE BEEN SUBMITTED</b>	YES	NO
<b>ARE YOU THE ACCREDITED REPRESENTATIVE IN SOUTH AFRICA FOR THE GOODS/SERVICES OFFERED BY YOU?</b>  (IF YES ENCLOSE PROOF)	YES	NO

**PART C  
PRICING SCHEDULE**

OFFER TO BE VALID FOR **90** DAYS FROM THE CLOSING DATE OF THE BID.

	<b>Amount</b>
<i>Section 1</i> - Preliminary & General	<b>R</b>
<i>Section 2</i> - pontoons - Repairs	<b>R</b>
<i>Section 3</i> - pontoons – New Alternative	<b>R</b>
<i>Section 4</i> - Top Structure	<b>R</b>
10% Contingency	<b>R</b>
15% VAT	<b>R</b>
TOTAL TENDER AMOUNT (VAT INCLUSIVE)	<b>R</b>

**\*NOTE:** Please refer to the Bill of Quantities in the specifications for the full pricing breakdown.

**PREFERENCE POINTS CLAIM FORM IN TERMS OF THE PREFERENTIAL PROCUREMENT REGULATIONS 2022 AND IN TERMS OF THE WESTERN CAPE GOVERNMENTS INTERIM STRATEGY AS IT RELATES TO PREFERENCE POINTS**

This preference form must form part of all bids invited. It contains general information and serves as a claim form for preference points for Broad-Based Black Economic Empowerment (B-BBEE) Status Level of Contribution.

**NB: BEFORE COMPLETING THIS FORM, BIDDERS (TENDERERS) MUST STUDY THE GENERAL CONDITIONS, DEFINITIONS AND DIRECTIVES APPLICABLE IN RESPECT OF THE TENDER, PREFERENTIAL PROCUREMENT REGULATIONS, 2022 AND THE BROAD BASED BLACK ECONOMIC EMPOWERMENT ACT AND THE CODES OF GOOD PRACTICE**

---

**1. DEFINITIONS**

- 1.1 “**acceptable tender**” means any tender which, in all respects, complies with the specifications and conditions of tender as set out in the tender document.
- 1.2 “**affidavit**” is a type of verified statement or showing, or in other words, it contains a verification, meaning it is under oath or penalty of perjury, and this serves as evidence to its veracity and is required for court proceedings.
- 1.3 “**all applicable taxes**” includes value-added tax, pay as you earn, income tax, unemployment insurance fund contributions and skills development levies;
- 1.4 “**B-BBEE**” means broad-based black economic empowerment as defined in section 1 of the Broad-Based Black Economic Empowerment Act;
- 1.5 “**B-BBEE status level of contributor**” means the B-BBEE status of an entity in terms of a code of good practice on black economic empowerment issued in terms of section 9(1) of the Broad-Based Black Economic Empowerment Act;
- 1.6 “**bid**” means a written offer on the official bid documents or invitation of price quotations and “**tender**” is the act of bidding/tendering;
- 1.7 “**Code of Good Practice**” means the generic codes or the sector codes as the case may be;
- 1.8 “**consortium or joint venture**” means an association of persons for the purpose of combining their expertise, property, capital, efforts, skill and knowledge in an activity for the execution of a contract;
- 1.9 “**contract**” means the agreement that results from the acceptance of a bid by an organ of state;
- 1.10 “**EME**” is an Exempted Micro Enterprise with an annual total revenue of R10 million or less.
- 1.11 “**Firm price**” means the price that is only subject to adjustments in accordance with the actual increase or decrease resulting from the change, imposition, or abolition of customs or excise duty and any other duty, levy, or tax, which, in terms of the law or regulation, is binding on the contractor and demonstrably has an influence on the price of any supplies, or the rendering costs of any service, for the execution of the contract;
- 1.12 “**Large Enterprise**” is any enterprise with an annual total revenue above R50 million;
- 1.13 “**non-firm prices**” means all prices other than “firm” prices;
- 1.14 “**person**” includes a juristic person;
- 1.15 “**price**” means an amount of money tendered for goods or services, and includes all applicable taxes less all unconditional discounts;

- 1.16 **“proof of B-BBEE status level contributor”** means-
- (a) The B-BBEE status level certificate issued by an authorized body or person;
  - (b) A sworn affidavit as prescribed in terms of the B-BBEE Codes of Good Practice; or
  - (c) Any other requirement prescribed in terms of the Broad-Based Black Economic Empowerment Act.
- 1.17 **QSE** is a Qualifying Small Enterprise with an annual total revenue between R10 million and R50 million;
- 1.18 **“rand value”** means the total estimated value of a contract in Rand, calculated at the time of the tender invitation; and includes all applicable taxes;
- 1.19 **“sub-contract”** means the primary contractor’s assigning, leasing, making out work to, or employing, another person to support such primary contractor in the execution of part of a project in terms of the contract.
- 1.20 **“tender”** means a written offer in the form determined by an organ of state in response to an invitation to provide or services through price quotations, competitive tendering process or any other method envisaged in legislation;
- 1.21 **“tender for income-generating contracts”** means a written offer in the form determined by an organ of state in response to an invitation for the origination of income-generating contracts through any method envisaged in legislation that will result in a legal agreement between the organ of state and a third party that produces revenue for the organ of state, and includes, but is not limited to, leasing and disposal of assets and concession contracts, excluding direct sales and disposal of assets through public auctions;
- 1.22 **“the Act”** means the Preferential Procurement Policy Framework Act, 2000 (Act No. 5 of 2000);
- 1.23 **“the Regulations”** means the Preferential Procurement Regulations, 2022;
- 1.24 **“total revenue”** bears the same meaning assigned to this expression in the Codes of Good Practice on Black Economic Empowerment, issued in terms of section 9(1) of the Broad-Based Black Economic Empowerment Act and promulgated in the Government Gazette on 11 October 2013;
- 1.25 **“trust”** means the arrangement through which the property of one person is made over or bequeathed to a trustee to administer such property for the benefit of another person; and
- 1.26 **“trustee”** means any person, including the founder of a trust, to whom property is bequeathed in order for such property to be administered for the benefit of another person.

## **2. GENERAL CONDITIONS**

- 2.1 The following preference point systems are applicable to all bids:
- the 80/20 system for requirements with a Rand value of up to R50 000 000 (all applicable taxes included); and
  - the 90/10 system for requirements with a Rand value above R50 000 000 (all applicable taxes included).
- 2.2 Preference point system for this bid:
- a) The value of this bid is estimated to not exceed R50 000 000 (all applicable taxes included) and therefore the 80/20 preference point system shall be applicable; or
  - b) The 80/20 preference point system will be applicable to this tender.
- 2.3 Preference points for this bid shall be awarded for:
- a) Price; and
  - b) B-BBEE Status Level of Contribution

2.4 The maximum points for this bid are allocated as follows:

	POINTS
PRICE	
B-BBEE STATUS LEVEL OF CONTRIBUTOR	
<b>Total points Price and B-BBEE must not exceed</b>	<b>100</b>

2.5 Failure on the part of a bidder to fill in, sign this form and submit in the circumstances prescribed in the Codes of Good Practice either a B-BBEE Verification Certificate issued by a Verification Agency accredited by the South African Accreditation System (SANAS) or an affidavit confirming annual total revenue and level of black ownership together with the bid or an affidavit issued by Companies Intellectual Property Commission, will be interpreted to mean that preference points for B-BBEE status level of contribution are not claimed.

2.6 The organ of state reserves the right to require of a bidder, either before a bid is adjudicated or at any time subsequently, to substantiate any claim in regard to preferences, in any manner required by the organ of state.

### 3. ADJUDICATION USING A POINT SYSTEM

3.1 Subject to Section 2(1)(f) of the Preferential Procurement Policy Framework Act, 2000, the bidder obtaining **the highest number of total points** will be awarded the contract.

3.2 A tenderer must submit proof of its B-BBEE status level of contributor in order to claim points for B-BBEE.

3.3 A tenderer failing to submit proof of B-BBEE status level of contributor or is a non-compliant contributor to B-BBEE will not be disqualified but will only score:

(a) points out of 80 for price; and

(b) 0 points out of 20 for B-BBEE

3.4 Points scored must be rounded off to the nearest 2 decimal places.

3.5 In the event that two or more bids have scored equal total points, the successful bid must be the one scoring the highest number of preference points for B-BBEE.

3.6 As per section 2(1)(f) of the Preferential Procurement Policy Framework Act, 2000, the contract may be awarded to a bidder other than the one scoring the highest number of total points based on objective criteria in addition to those contemplated in paragraphs (d) and (e) of the Preferential Procurement Policy Framework Act, 2000 that justifies the award to another tenderer provided that it has been stipulated upfront in the tendering conditions.

3.7 Should two or more bids be equal in all respects; the award shall be decided by the drawing of lots.

#### 4. FORMULAE FOR PROCUREMENT OF GOODS AND SERVICES

##### 4.1 POINTS AWARDED FOR PRICE

###### 4.1.1 THE 80/20 OR 90/10 PREFERENCE POINT SYSTEM

A maximum of 80 or 90 points is allocated for price on the following basis:

80/20 or 90/10

$$Ps = 80 \left( 1 - \frac{Pt - Pmin}{Pmin} \right) \quad \text{or} \quad Ps = 90 \left( 1 - \frac{Pt - Pmin}{Pmin} \right)$$

Where

Ps = Points scored for price of bid under consideration

Pt = Price of tender under consideration

Pmin = Price of lowest acceptable tender

#### 5. FORMULAE FOR DISPOSAL OR LEASING OF STATE ASSETS AND INCOME GENERATING PROCUREMENT

##### 5.1 POINTS AWARDED FOR PRICE

A maximum of 80 or 90 points is allocated for price on the following basis:

80/20 or 90/10

$$Ps = 80 \left( 1 - \frac{Pt - Pmax}{Pmax} \right) \quad \text{or} \quad Ps = 90 \left( 1 - \frac{Pt - Pmax}{Pmax} \right)$$

Where

Ps = Points scored for price of bid under consideration

Pt = Price of tender under consideration

Pmax = Price of highest acceptable tender

## 6. POINTS AWARDED FOR B-BBEE STATUS LEVEL OF CONTRIBUTION

- 6.1 In terms of WCG interim strategy, preference points must be awarded to a bidder for attaining the B-BBEE status level of contribution in accordance with the table below:

B-BBEE Status Level of Contributor	Number of points (90/10 system)	Number of points (80/20 system)
1	10	20
2	9	18
3	6	14
4	5	12
5	4	8
6	3	6
7	2	4
8	1	2
Non-compliant contributor	0	0

- 6.2 An **EME** must submit a valid, originally certified affidavit confirming annual turnover and level of black ownership or an affidavit issued by Companies Intellectual Property Commission.
- 6.3 A **QSE that is less than 51 per cent (50% or less) black owned** must be verified in terms of the QSE scorecard issued via Government Gazette and submit a valid, original or a legible certified copy of a B-BBEE Verification Certificate issued by SANAS.
- 6.4 A **QSE that is at least 51 per cent black owned (51% or higher)** must submit a valid, originally certified affidavit confirming turnover and level of black ownership as well as declare its empowering status or an affidavit issued by Companies Intellectual Property Commission.
- 6.5 A **large enterprise** must submit a valid, original or originally certified copy of a B-BBEE Verification Certificate issued by a verification agency accredited by SANAS.
- 6.6 A trust, consortium or joint venture, will qualify for points for their B-BBEE status level as a legal entity, provided that the entity submits their B-BBEE status level certificate.
- 6.7 A trust, consortium or joint venture (including unincorporated consortia and joint ventures) must submit a consolidated B-BBEE status level verification certificate for every separate tender.
- 6.8 Tertiary institutions and public entities will be required to submit their B-BBEE status level certificates in terms of the specialized scorecard contained in the B-BBEE Codes of Good Practice.

## 7. BID DECLARATION

- 7.1 Bidders who claim points in respect of B-BBEE Status Level of Contribution must complete the following:

## 8. B-BBEE STATUS LEVEL OF CONTRIBUTION CLAIMED IN TERMS OF PARAGRAPH 6

- 8.1 B-BBEE Status Level of Contribution ..... = ..... (maximum of 20 points)

(Points claimed in respect of paragraph 7.1 must be in accordance with the table reflected in paragraph 6.1 and must be substantiated by means of a B-BBEE certificate issued by a Verification Agency accredited by SANAS or an affidavit confirming annual total revenue and level of black ownership in terms of the relevant sector code applicable to the tender.

**9. SUB-CONTRACTING**

9.1 Will any portion of the contract be sub-contracted? **YES / NO**

9.1.1 If yes, indicate:

(i) what percentage of the contract will be subcontracted? .....%

(ii) the name of the sub-contractor? .....

(iii) the B-BBEE status level of the sub-contractor? .....

(iv) whether the sub-contractor is an EME or QSE? **YES / NO**

9.1.2 Sub-contracting relates to a **particular** contract and if sub-contracting is applicable, the bidder to state in their response to a particular RFQ that a portion of that contract will be sub-contracted.

**10. DECLARATION WITH REGARD TO COMPANY/FIRM**

10.1 Name of company/entity : .....

10.2 VAT registration number : .....

10.3 Company Registration number : .....

10.4 TYPE OF COMPANY/FIRM

Partnership/ Joint Venture/ Consortium

One-person business/ sole propriety

Close corporation

Public Company

Personal Liability Company

(Pty) Limited

Non-Profit Company

State Owned Company

[SELECT APPLICABLE ONE]

10.5 I/we, the undersigned, who is / are duly authorised to do so on behalf of the company/firm, certify that the points claimed, based on the B-BBEE status level of contribution indicated in paragraph 7 above, qualifies the company/ firm for the preference(s) shown and I / we acknowledge that:

(a) The Western Cape Government reserves the right to audit the B-BBEE status claim submitted by the bidder.

(b) As set out in Section 130 of the B-BBEE Act as amended, any misrepresentation constitutes a criminal offence. A person commits an offence if that person knowingly:

(i) misrepresents or attempts to misrepresent the B-BBEE status of an enterprise;

(ii) provides false information or misrepresents information to a B-BBEE Verification Professional in order to secure a particular B-BBEE status or any benefit associated with compliance to the B-BBEE Act;

- (iii) provides false information or misrepresents information relevant to assessing the B-BBEE status of an enterprise to any organ of state or public entity; or
  - (iv) engages in a fronting practice.
- (c) If a B-BBEE verification professional or any procurement officer or other official of an organ of state or public entity becomes aware of the commission of, or any attempt to commit any offence referred to in paragraph 10.5 (a) above will be reported to an appropriate law enforcement agency for investigation.
- (d) Any person convicted of an offence by a court is liable in the case of contravention of 10.5 (b) to a fine or to imprisonment for a period not exceeding 10 years or to both a fine and such imprisonment or, if the convicted person is not a natural person to a fine not exceeding 10 per cent of its annual turnover.
- (e) The purchaser may, if it becomes aware that a bidder may have obtained its B-BBEE status level of contribution on a fraudulent basis, investigate the matter. Should the investigation warrant a restriction be imposed, this will be referred to the National Treasury for investigation, processing and imposing the restriction on the National Treasury's List of Restricted Suppliers. The bidder or contractor, its shareholders and directors, or only the shareholders and directors who acted on a fraudulent basis, may be restricted from obtaining business from any organ of state for a period not exceeding 10 years, after the audi alteram partem (hear the other side) rule has been applied.
- (f) The purchaser may, in addition to any other remedy it may have –
- (i) disqualify the person from the bidding process;
  - (ii) recover costs, losses or damages it has incurred or suffered as a result of that person's conduct;
  - (iii) cancel the contract and claim any damages which it has suffered as a result of having to make less favourable arrangements due to such cancellation; and
  - (iv) forward the matter for criminal prosecution.
- (g) The information furnished is true and correct.
- (h) The preference points claimed are in accordance with the General Conditions as indicated in paragraph 2 of this form.

**SIGNATURE(S) OF THE BIDDER(S):** .....

**DATE:** .....

**ADDRESS:** .....

.....

**WITNESSES:**

1. ....

2. ....

**PROVINCIAL GOVERNMENT OF WESTERN CAPE**

**DECLARATION OF INTERESTS, BIDDERS PAST SCM PRACTICES AND INDEPENDENT BID DETERMINATION**

1. To give effect to the requirements of the Western Cape Provincial Treasury Instructions, 2019: Supply Chain Management (Goods and Services), Public Finance Management Act (PFMA) Supply Chain Management (SCM) Instruction No. 3 of 2021/2022 - SBD 4 Declaration of Interest, Section 4 (1)(b)(iii) of the Competition Act No. 89 of 1998 as amended together with its associated regulations, the Prevention and Combating of Corrupt Activities Act No 12 of 2004 and regulations pertaining to the tender defaulters register, Paragraph 16A9 of the National Treasury Regulations and/or any other applicable legislation.
2. Any person (natural or juristic) may make an offer or offers in terms of this invitation to bid. In line with the principles of transparency, accountability, impartiality, and ethics as enshrined in the Constitution of the Republic of South Africa and further expressed in various pieces of legislation, it is required for the bidder to make this declaration in respect of the details required hereunder.
3. All prospective bidders intending to do business with the Institution must be registered on the Central Supplier Database (CSD) and the Western Cape Supplier Evidence Bank (WCSEB) if they wish to do business with the Western Cape Government (WCG) via the electronic Procurement Solution (ePS).
4. The status of enterprises and persons listed on the National Treasury's Register for Tender Defaulters will be housed on the ePS. Institutions may not under any circumstances procure from enterprises and persons listed on the Database of Tender Defaulters.
5. The status of suppliers listed on the National Treasury's Database of Restricted Suppliers will be housed on the ePS; however, it remains incumbent on institutions to check the National Treasury Database of Restricted Suppliers before the conclusion of any procurement process. For suppliers listed as restricted, institutions must apply due diligence and risk assessment before deciding to proceed with procurement from any such supplier.
6. **Definitions**

"**bid**" means a bidder's response to an institution's invitation to participate in a procurement process which may include a bid, price quotation or proposal;

"**Bid rigging (or collusive bidding)**" occurs when businesses, that would otherwise be expected to compete, secretly conspire to raise prices or lower the quality of goods and / or services for purchasers who wish to acquire goods and/or services through a bidding process. Bid rigging is, therefore, an agreement between competitors;

"**business interest**" means -

  - (a) a right or entitlement to share in profits, revenue or assets of an entity;
  - (b) a real or personal right in property;
  - (c) a right to remuneration or any other private gain or benefit, or
  - (d) includes any interest contemplated in paragraphs (a), (b) or (c) acquired through an intermediary and any potential interest in terms of any of those paragraphs;

"**Consortium or Joint Venture**" means an association of persons for the purpose of combining their expertise, property, capital, efforts, skill and knowledge in an activity for the execution of a contract;

"**Controlling interest**" means, the power, by one person or a group of persons holding the majority of the equity of an enterprise, alternatively, the person/s having the deciding vote or power to influence or to direct the course and decisions of the enterprise;

**“Corruption”**- General offences of corruption are defined in the Combating of Corrupt Activities Act, 2004 (Act No 12 of 2004) as:

Any person who directly or indirectly-

- (a) accepts or agrees or offers to accept an! gratification from any other person, whether for the benefit of himself or herself or for the benefit of another person; or
- (b) gives or agrees or offers to give to any other person any gratification, whether for the benefit of that other person or for the benefit of another person., in order to act personally or by influencing another person so to act, in a manner—
  - (i) that amounts to the-
    - (aa) illegal. dishonest. unauthorised. incomplete. or biased: or
    - (bb) misuse or selling of information or material acquired in the course of the exercise, carrying out or performance of any powers, duties or functions arising out of a constitutional, statutory, contractual or any other legal obligation:
  - (ii) that amounts to-
    - (aa) the abuse of a position of authority;
    - (bb) a breach of trust; or
    - (cc) the violation of a legal duty or a set of rules;
  - (iii) designed to achieve an unjustified result; or
  - (iv) that amounts to any other unauthorised or improper inducement to do or 45 not to do anything. of the, is guilty of the offence of corruption

**“CSD”** means the Central Supplier Database maintained by National Treasury;

**“employee”**, in relation to –

- (a) a department, means a person contemplated in section 8 of the Public Service Act, 1994 but excludes a person appointed in terms of section 12A of that Act; and
- (b) a public entity, means a person employed by the public entity;

**“entity”** means any -

- (a) association of persons, whether or not incorporated or registered in terms of any law, including a company, corporation, trust, partnership, close corporation, joint venture or consortium; or
- (b) sole proprietorship;

**“entity conducting business with the Institution”** means an entity that contracts or applies or tenders for the sale, lease or supply of goods or services to the Province;

**“Family member”** means a person’s -

- (a) spouse; or
- (b) child, parent, brother, sister, whether such a relationship results from birth, marriage or adoption or some other legal arrangement (as the case may be);

**“intermediary”** means a person through whom an interest is acquired, and includes a representative or agent or any other person who has been granted authority to act on behalf of another person;

**“Institution”** means –

a provincial department or provincial public entity listed in Schedule 3C of the Act; **“Provincial**

**Government Western Cape (PGWC)”** means

(a) the Institution of the Western Cape, and

(b) a provincial public entity;

**“RWOEE”** means -

Remunerative Work Outside of the Employee’s Employment

**“spouse”** means a person’s -

(a) partner in marriage or civil union according to legislation;

(b) partner in a customary union according to indigenous law; or

(c) partner with whom he or she cohabits and who is publicly acknowledged by the person as his or her life partner or permanent companion.

7. Regulation 13(c) of the Public Service Regulations (PSR) 2016, effective 1 February 2017, prohibits any employee from conducting business with an organ of state, or holding a directorship in a public or private company doing business with an organ of state unless the employee is a director (in an official capacity) of a company listed in schedules 2 and 3 of the Public Finance Management Act.

a) Therefore, by 31 January 2017 all employees who are conducting business with an organ of state should either have:

(i) resigned as an employee of the government institution or;

(ii) cease conducting business with an organ of state or;

(iii) resign as a director/shareholder/owner/member of an entity that conducts business with an organ of state.

8. Any legal person, or their family members, may make an offer or offers in terms of this invitation to bid. In view of potential conflict of interest, in the event that the resulting bid, or part thereof, be awarded to family members of persons employed by an organ of state, it is required that the bidder or his/her authorised representative declare his/her position in relation to the evaluating/adjudicating authority where the bidder is employed by the Institution

9. The bid of any bidder may be disregarded if that bidder or any of its directors abused the institution’s supply chain management system; committed fraud or any other improper conduct in relation to such system; or failed to perform on any previous contract.

10. Section 4 (1) (b) (iii) of the Competition Act No. 89 of 1998, as amended, prohibits an agreement between, or concerted practice by firms, or a decision by an association of firms, if it is between parties in a horizontal relationship and if it involves collusive bidding (or bid rigging). Collusive bidding is a per se prohibition meaning that it cannot be justified under any grounds.

11. Treasury Regulation 16A9 prescribes that accounting officers and accounting authorities must take all reasonable steps to prevent abuse of the supply chain management system and authorises accounting officers and accounting authorities to:





**SECTION C: PERFORMANCE MANAGEMENT AND BIDDER'S PAST SUPPLY CHAIN MANAGEMENT PRACTICES**

To enable the prospective bidder to provide evidence of past and current performance.

<b>C1.</b>	Did the entity conduct business with an organ of state in the last twelve months? (If yes complete Table C)	NO	YES
------------	--	----	-----

**C2. TABLE C**

Complete the below table to the maximum of the last 5 contracts.

NAME OF CONTRACTOR	PROVINCIAL DEPARTMENT OR PROVINCIAL ENTITY	TYPE OF SERVICES OR COMMODITY	CONTRACT/ ORDER NUMBER	PERIOD OF CONTRACT	VALUE OF CONTRACT	
<b>C3.</b>	Is the entity or its principals listed on the National Database as companies or persons prohibited from doing business with the public sector?				NO	YES
<b>C4.</b>	Is the entity or its principals listed on the National Treasury Register for Tender Defaulters in terms of section 29 of the Prevention and Combating of Corrupt Activities Act (No. 12 of 2004)?  (To access this Register enter the National Treasury's website, <a href="http://www.treasury.gov.za">www.treasury.gov.za</a> , click on the icon "Register for Tender Defaulters" or submit your written request for a hard copy of the Register to facsimile number (012) 326 5445.)				NO	YES
<b>C5.</b>	If yes to C3 or C4, were you informed in writing about the listing on the database of restricted suppliers or Register for Tender Defaulters by National Treasury?			NO	YES	N/A
<b>C6.</b>	Was the entity or persons listed in Table A convicted for fraud or corruption during the past five years in a court of law (including a court outside the Republic of South Africa)?				NO	YES
<b>C7.</b>	Was any contract between the bidder and any organ of state terminated during the past five years on account of failure to perform on or comply with the contract?				NO	YES

**SECTION D: DULY AUTHORISED REPRESENTATIVE TO DEPOSE TO AFFIDAVIT**

This form must be signed by a duly authorised representative of the entity in the presence of a commissioner of oaths.

I, ..... hereby swear/affirm;

- i. that the information disclosed above is true and accurate;
- ii. that I have read understand the content of the document;
- iii. that I have arrived at the accompanying bid independently from, and without consultation, communication, agreement or arrangement with any competitor.
- iv. that the entity undertakes to independently arrive at any offer at any time to the Institution without any consultation, communication, agreement or arrangement with any competitor. In addition, that there will be no consultations, communications, agreements or arrangements with any competitor regarding the quality, quantity, specification, prices, including methods, factors or formulas used to calculate prices, market allocation, the intention or decision to submit or not to submit the bid, bidding with the intention not to win the bid and conditions or delivery particulars of the products or services to which this bid invitation relates;
- v. that the entity or its representative are aware of and undertakes not to disclose the terms of any bid, formal or informal, directly or indirectly, to any competitor, prior to the date and time of the official bid opening or of the awarding of the contract; and
- vi. that there have been no consultations, communications, agreements or arrangements made with any official of the procuring institution in relation to this procurement process prior to and during the bidding process except to provide clarification on the bid submitted where so required by the institution; and that my entity was not involved in the drafting of the specifications or terms of reference for this bid.

.....

**DULY AUTHORISED REPRESENTATIVE'S**

**SIGNATURE**

I certify that before administering the oath/affirmation I asked the deponent the following questions and wrote down his/her answers in his/her presence:

- 1.1 Do you know and understand the contents of the declaration? ANSWER: .....
- 1.2 Do you have any objection to taking the prescribed oath? ANSWER: .....
- 1.3 Do you consider the prescribed oath to be binding on your conscience? ANSWER:.....
- 1.4 Do you want to make an affirmation? ANSWER: .....

2. I certify that the deponent has acknowledged that he/she knows and understands the contents of this declaration, which was sworn to/affirmed and the deponent's signature/thumbprint/mark was place thereon in my presence.

.....

**SIGNATURE FULL NAMES:** Commissioner of Oaths

**Designation** (rank):.....ex officio: Republic of South Africa

**Date:** ..... **Place:** .....

**Business Address:** .....

.....

## GENERAL CONDITIONS OF CONTRACT

### NOTES

The purpose of this document is to:

- (i) Draw special attention to certain general conditions applicable to government bids, contracts and orders; and
  - (ii) To ensure that clients be familiar with regard to the rights and obligations of all parties involved in doing business with government. In this document words in the singular also mean in the plural and vice versa and words in the masculine also mean in the feminine and neuter.
- The General Conditions of Contract will form part of all bid documents and may not be amended.
- Special Conditions of Contract (SCC) relevant to a specific bid should be compiled separately for every bid (if applicable) and will supplement the General Conditions of Contract. Whenever there is a conflict, the provisions in the SCC shall prevail.

### General Conditions of Contract

**1. Definitions** 1. The following terms shall be interpreted as indicated:

1.1 "Closing time" means the date and hour specified in the bidding documents for the receipt of bids.

1.2 "Contract" means the written agreement entered into between the purchaser and the supplier, as recorded in the contract form signed by the parties, including all attachments and appendices thereto and all documents incorporated by reference therein.

1.3 "Contract price" means the price payable to the supplier under the contract for the full and proper performance of his contractual obligations.

1.4 "Corrupt practice" means the offering, giving, receiving, or soliciting of anything of value to influence the action of a public official in the procurement process or in contract execution.

1.5 "Countervailing duties" are imposed in cases where an enterprise abroad is subsidized by its government and encouraged to market its products internationally.

1.6 "Country of origin" means the place where the goods were mined, grown or produced or from which the services are supplied. Goods are produced when, through manufacturing, processing or substantial and major assembly of components, a commercially recognized new product results that is substantially different in basic characteristics or in purpose or utility from its components.

1.7 "Day" means calendar day.

1.8 "Delivery" means delivery in compliance of the conditions of the contract or order.

1.9 "Delivery ex stock" means immediate delivery directly from stock actually on hand.

1.10 "Delivery into consignees store or to his site" means delivered and unloaded in the specified store or depot or on the specified site in compliance with the conditions of the contract or order, the supplier bearing all risks and charges involved until the supplies are so delivered and a valid receipt is obtained.

1.11 "Dumping" occurs when a private enterprise abroad market its goods on own initiative in the RSA at lower prices than that of the country of origin and which have the potential to harm the local industries in the RSA.

1.12 "Force majeure" means an event beyond the control of the supplier and not involving the supplier's fault or negligence and not foreseeable. Such events may include, but is not restricted to, acts of the purchaser in its sovereign capacity, wars or revolutions, fires, floods, epidemics, quarantine restrictions and freight embargoes.

1.13 "Fraudulent practice" means a misrepresentation of facts in order to influence a procurement process or the execution of a contract to the detriment of any bidder, and includes collusive practice among bidders (prior to or after bid submission) designed to establish bid prices at artificial non-competitive levels and to deprive the bidder of the benefits of free and open competition.

1.14 "GCC" means the General Conditions of Contract.

1.15 "Goods" means all of the equipment, machinery, and/or other materials that the supplier is required to supply to the purchaser under the contract.

1.16 "Imported content" means that portion of the bidding price represented by the cost of components, parts or materials which have been or are still to be imported (whether by the supplier or his subcontractors) and which costs are inclusive of the costs abroad, plus freight and other direct importation costs such as landing costs, dock dues, import duty, sales duty or other similar tax or duty at the South African place of entry as well as transportation and handling charges to the factory in the Republic where the supplies covered by the bid will be manufactured.

1.17 "Local content" means that portion of the bidding price which is not included in the imported content provided that local manufacture does take place.

1.18 "Manufacture" means the production of products in a factory using labour, materials, components and machinery and includes other related value-adding activities.

1.19 "Order" means an official written order issued for the supply of goods or works or the rendering of a service.

1.20 "Project site," where applicable, means the place indicated in bidding documents.

1.21 "Purchaser" means the organization purchasing the goods.

1.22 "Republic" means the Republic of South Africa.

1.23 "SCC" means the Special Conditions of Contract.

1.24 "Services" means those functional services ancillary to the supply of the goods, such as transportation and any other incidental services, such as installation, commissioning, provision of technical assistance, training, catering, gardening, security, maintenance and other such obligations of the supplier covered under the contract.

1.25 "Written" or "in writing" means handwritten in ink or any form of electronic or mechanical writing.

## **2. Application**

2.1 These general conditions are applicable to all bids, contracts and orders including bids for functional and professional services, sales, hiring, letting and the granting or acquiring of rights, but excluding

immovable property, unless otherwise indicated in the bidding documents.

2.2 Where applicable, special conditions of contract are also laid down to cover specific supplies, services or works.

2.3 Where such special conditions of contract are in conflict with these general conditions, the special conditions shall apply.

## **3. General**

3.1 Unless otherwise indicated in the bidding documents, the purchaser shall not be liable for any expense incurred in the preparation and submission of a bid. Where applicable a non-refundable fee for documents may be charged.

3.2 With certain exceptions, invitations to bid are only published in the Government Tender Bulletin. The Government Tender Bulletin may be obtained directly from the Government Printer, Private Bag X85,

Pretoria 0001, or accessed electronically from [www.treasury.gov.za](http://www.treasury.gov.za)

#### **4. Standards**

4.1 The goods supplied shall conform to the standards mentioned in the bidding documents and specifications.

#### **5. Use of contract documents and information; inspection.**

5.1 The supplier shall not, without the purchaser's prior written consent, disclose the contract, or any provision thereof, or any specification, plan, drawing, pattern, sample, or information furnished by or on behalf of the purchaser in connection therewith, to any person other than a person employed by the supplier in the performance of the contract. Disclosure to any such employed person shall be made in confidence and shall extend only so far as may be necessary for purposes of such performance.

5.2 The supplier shall not, without the purchaser's prior written consent, make use of any document or information mentioned in GCC clause

5.1 except for purposes of performing the contract.

5.3 Any document, other than the contract itself mentioned in GCC clause

5.1 shall remain the property of the purchaser and shall be returned (all copies) to the purchaser on completion of the supplier's performance under the contract if so required by the purchaser.

5.4 The supplier shall permit the purchaser to inspect the supplier's records relating to the performance of the supplier and to have them audited by auditors appointed by the purchaser, if so required by the purchaser.

#### **6. Patent rights**

6.1 The supplier shall indemnify the purchaser against all third-party claims of infringement of patent, trademark, or industrial design rights arising from use of the goods or any part thereof by the purchaser.

#### **7. Performance security**

7.1 Within thirty (30) days of receipt of the notification of contract award, the successful bidder shall furnish to the purchaser the performance security of the amount specified in SCC.

7.2 The proceeds of the performance security shall be payable to the purchaser as compensation for any loss resulting from the supplier's failure to complete his obligations under the contract.

7.3 The performance security shall be denominated in the currency of the contract, or in a freely convertible currency acceptable to the purchaser and shall be in one of the following forms:

(a) a bank guarantee or an irrevocable letter of credit issued by a reputable bank located in the purchaser's country or abroad, acceptable to the purchaser, in the form provided in the bidding documents or another form acceptable to the purchaser; or

(b) a cashier's or certified cheque

7.4 The performance security will be discharged by the purchaser and returned to the supplier not later than thirty (30) days following the date of completion of the supplier's performance obligations under the contract, including any warranty obligations, unless otherwise specified in SCC.

#### **8. Inspections, tests and analyses**

8.1 All pre-bidding testing will be for the account of the bidder.

8.2 If it is a bid condition that supplies to be produced or services to be rendered should at any stage during production or execution or on completion be subject to inspection, the premises of the bidder or contractor shall be open, at all reasonable hours, for inspection by a representative of the Department or an organization acting on behalf of the Department.

8.3 If there are no inspection requirements indicated in the bidding documents and no mention is made in the contract, but during the contract period it is decided that inspections shall be carried out, the purchaser shall itself make the necessary arrangements, including payment arrangements with the testing authority concerned.

8.4 If the inspections, tests and analyses referred to in clauses 8.2 and 8.3 show the supplies to be in accordance with the contract requirements, the cost of the inspections, tests and analyses shall be defrayed by the purchaser.

8.5 Where the supplies or services referred to in clauses 8.2 and 8.3 do not comply with the contract requirements, irrespective of whether such supplies or services are accepted or not, the cost in connection with these inspections, tests or analyses shall be defrayed by the supplier.

8.6 Supplies and services which are referred to in clauses 8.2 and 8.3 and which do not comply with the contract requirements may be rejected.

8.7 Any contract supplies may on or after delivery be inspected, tested or analysed and may be rejected if found not to comply with the requirements of the contract. Such rejected supplies shall be held at the cost and risk of the supplier who shall, when called upon, remove them immediately at his own cost and forthwith substitute them with supplies which do comply with the requirements of the contract. Failing such removal the rejected supplies shall be returned at the suppliers cost and risk. Should the supplier fail to provide the substitute supplies forthwith, the purchaser may, without giving the supplier further opportunity to substitute the rejected supplies, purchase such supplies as may be necessary at the expense of the supplier.

8.8 The provisions of clauses 8.4 to 8.7 shall not prejudice the right of the purchaser to cancel the contract on account of a breach of the conditions thereof, or to act in terms of Clause 23 of GCC.

## **9. Packing**

9.1 The supplier shall provide such packing of the goods as is required to prevent their damage or deterioration during transit to their final destination, as indicated in the contract. The packing shall be sufficient to withstand, without limitation, rough handling during transit and exposure to extreme temperatures, salt and precipitation

during transit, and open storage. Packing, case size and weights shall take into consideration, where appropriate, the remoteness of the goods' final destination and the absence of heavy handling facilities at all points in transit.

9.2 The packing, marking, and documentation within and outside the packages shall comply strictly with such special requirements as shall be expressly provided for in the contract, including additional requirements, if any, specified in SCC, and in any subsequent instructions ordered by the purchaser.

## **10. Delivery and documents**

10.1 Delivery of the goods shall be made by the supplier in accordance with the terms specified in the contract. The details of shipping and/or other documents to be furnished by the supplier are specified in SCC.

10.2 Documents to be submitted by the supplier are specified in SCC.

## **11. Insurance**

11.1 The goods supplied under the contract shall be fully insured in a freely convertible currency against loss or damage incidental to manufacture or acquisition, transportation, storage and delivery in the manner specified in the SCC.

## **12. Transportation**

12.1 Should a price other than an all-inclusive delivered price be required, this shall be specified in the SCC.

## **13. Incidental services**

13.1 The supplier may be required to provide any or all of the following services, including additional services, if any, specified in SCC:

(a) performance or supervision of on-site assembly and/or commissioning of the supplied goods;

(b) furnishing of tools required for assembly and/or maintenance of the supplied goods;

(c) furnishing of a detailed operations and maintenance manual for each appropriate unit of the supplied goods;

(d) performance or supervision or maintenance and/or repair of the supplied goods, for a period of time agreed by the parties, provided that this service shall not relieve the supplier of any warranty obligations under this contract; and

(e) training of the purchaser's personnel, at the supplier's plant and/or on-site, in assembly, start-up, operation, maintenance, and/or repair of the supplied goods.

13.2 Prices charged by the supplier for incidental services, if not included in the contract price for the goods, shall be agreed upon in advance by the parties and shall not exceed the prevailing rates charged to other parties by the supplier for similar services.

#### **14. Spare parts**

14.1 As specified in SCC, the supplier may be required to provide any or all of the following materials, notifications, and information pertaining to spare parts manufactured or distributed by the supplier:

(a) such spare parts as the purchaser may elect to purchase from the supplier, provided that this election shall not relieve the supplier of any warranty obligations under the contract; and

(b) in the event of termination of production of the spare parts:

(i) Advance notification to the purchaser of the pending termination, in sufficient time to permit the purchaser to procure needed requirements; and

(ii) following such termination, furnishing at no cost to the purchaser, the blueprints, drawings, and specifications of the spare parts, if requested.

#### **15. Warranty**

15.1 The supplier warrants that the goods supplied under the contract are new, unused, of the most recent or current models, and that they incorporate all recent improvements in design and materials unless provided otherwise in the contract. The supplier further warrants that all goods supplied under this contract shall have no defect, arising from design, materials, or workmanship (except when the design and/or material is required by the purchaser's specifications) or from any act or omission of the supplier, that may develop under normal use of the supplied goods in the conditions prevailing in the country of final destination.

15.2 This warranty shall remain valid for twelve (12) months after the goods, or any portion thereof as the case may be, have been delivered to and accepted at the final destination indicated in the contract, or for eighteen (18) months after the date of shipment from the port or place of loading in the source country, whichever period concludes earlier, unless specified otherwise in SCC.

15.3 The purchaser shall promptly notify the supplier in writing of any claims arising under this warranty.

15.4 Upon receipt of such notice, the supplier shall, within the period specified in SCC and with all reasonable speed, repair or replace the defective goods or parts thereof, without costs to the purchaser.

15.5 If the supplier, having been notified, fails to remedy the defect(s) within the period specified in SCC, the purchaser may proceed to take such remedial action as may be necessary, at the supplier's risk and expense and without prejudice to any other rights which the purchaser may have against the supplier under the contract.

#### **16. Payment**

16.1 The method and conditions of payment to be made to the supplier under this contract shall be specified in SCC.

16.2 The supplier shall furnish the purchaser with an invoice accompanied by a copy of the delivery note and upon fulfillment of other obligations stipulated in the contract.

16.3 Payments shall be made promptly by the purchaser, but in no case later than thirty (30) days after submission of an invoice or claim by the supplier.

16.4 Payment will be made in Rand unless otherwise stipulated in SCC.

## **17. Prices**

17.1 Prices charged by the supplier for goods delivered and services performed under the contract shall not vary from the prices quoted by the supplier in his bid, with the exception of any price adjustments authorized in SCC or in the purchaser's request for bid validity extension, as the case may be.

## **18. Contract amendments**

18.1 No variation in or modification of the terms of the contract shall be made except by written amendment signed by the parties concerned.

## **19. Assignment**

19.1 The supplier shall not assign, in whole or in part, its obligations to perform under the contract, except with the purchaser's prior written consent.

## **20. Subcontracts**

20.1 The supplier shall notify the purchaser in writing of all subcontracts awarded under this contracts if not already specified in the bid. Such notification, in the original bid or later, shall not relieve the supplier from any liability or obligation under the contract.

## **21. Delays in the supplier's performance**

21.1 Delivery of the goods and performance of services shall be made by the supplier in accordance with the time schedule prescribed by the purchaser in the contract.

21.2 If at any time during performance of the contract, the supplier or its subcontractor(s) should encounter conditions impeding timely delivery of the goods and performance of services, the supplier shall promptly notify the purchaser in writing of the fact of the delay, its likely duration and its cause(s). As soon as practicable after receipt of the supplier's notice, the purchaser shall evaluate the situation and may at his discretion extend the supplier's time for performance, with or without the imposition of penalties, in which case the extension shall be ratified by the parties by amendment of contract.

21.3 No provision in a contract shall be deemed to prohibit the obtaining of supplies or services from a national department, provincial department, or a local authority.

21.4 The right is reserved to procure outside of the contract small quantities or to have minor essential services executed if an emergency arises, the supplier's point of supply is not situated at or near the place where the supplies are required, or the supplier's services are not readily available.

21.5 Except as provided under GCC Clause 25, a delay by the supplier in the performance of its delivery obligations shall render the supplier liable to the imposition of penalties, pursuant to GCC Clause 22, unless an extension of time is agreed upon pursuant to GCC Clause 21.2 without the application of penalties.

21.6 Upon any delay beyond the delivery period in the case of a supplies contract, the purchaser shall, without cancelling the contract, be entitled to purchase supplies of a similar quality and up to the same quantity in substitution of the goods not supplied in conformity with the contract and to return any goods delivered later at the supplier's expense and risk, or to cancel the contract and buy such goods as may be required to complete the contract and without prejudice to his other rights, be entitled to claim damages from the supplier.

## **22. Penalties**

22.1 Subject to GCC Clause 25, if the supplier fails to deliver any or all of the goods or to perform the services within the period(s) specified in the contract, the purchaser shall, without prejudice to its other remedies under the contract, deduct from the contract price, as a penalty, a sum calculated on the delivered price of the delayed goods or unperformed services using the current prime interest rate calculated for each day of the delay until actual delivery or performance. The purchaser may also consider termination of the contract pursuant to GCC Clause 23.

## **23. Termination for default**

23.1 The purchaser, without prejudice to any other remedy for breach of contract, by written notice of default sent to the supplier, may terminate this contract in whole or in part:

- (a) if the supplier fails to deliver any or all of the goods within the period(s) specified in the contract, or within any extension thereof granted by the purchaser pursuant to GCC Clause 21.2;
- (b) if the Supplier fails to perform any other obligation(s) under the contract; or
- (c) if the supplier, in the judgment of the purchaser, has engaged in corrupt or fraudulent practices in competing for or in executing the contract.

23.2 In the event the purchaser terminates the contract in whole or in part, the purchaser may procure, upon such terms and in such manner as it deems appropriate, goods, works or services similar to those undelivered, and the supplier shall be liable to the purchaser for any excess costs for such similar goods, works or services. However, the supplier shall continue performance of the contract to the extent not terminated.

23.3 Where the purchaser terminates the contract in whole or in part, the purchaser may decide to impose a restriction penalty on the supplier by prohibiting such supplier from doing business with the public sector for a period not exceeding 10 years.

23.4 If a purchaser intends imposing a restriction on a supplier or any person associated with the supplier, the supplier will be allowed a time period of not more than fourteen (14) days to provide reasons why the envisaged restriction should not be imposed. Should the supplier fail to respond within the stipulated fourteen (14) days the purchaser may regard the intended penalty as not objected against and may impose it on the supplier.

23.5 Any restriction imposed on any person by the Accounting Officer / Authority will, at the discretion of the Accounting Officer / Authority, also be applicable to any other enterprise or any partner, manager, director or other person who wholly or partly exercises or exercised or may exercise control over the enterprise of the first-mentioned person, and with which enterprise or person the first-mentioned person, is or was in the opinion of the Accounting Officer / Authority actively associated.

23.6 If a restriction is imposed, the purchaser must, within five (5) working days of such imposition, furnish the National Treasury, with the following information:

- (i) the name and address of the supplier and / or person restricted by the purchaser;
- (ii) the date of commencement of the restriction
- (iii) the period of restriction; and
- (iv) the reasons for the restriction.

These details will be loaded in the National Treasury's central database of suppliers or persons prohibited from doing business with the public sector.

23.7 If a court of law convicts a person of an offence as contemplated in sections 12 or 13 of the Prevention and Combating of Corrupt Activities Act, No. 12 of 2004, the court may also rule that such person's name be endorsed on the Register for Tender Defaulters. When a person's name has been endorsed on the Register, the person will be prohibited from doing business with the public sector for a period not less than five years and not more than 10 years. The National

Treasury is empowered to determine the period of restriction and each case will be dealt with on its own merits. According to section 32 of the Act the Register must be open to the public. The Register can be perused on the National Treasury website.

#### **24. Anti-dumping and countervailing duties and rights**

24.1 When, after the date of bid, provisional payments are required, or antidumping or countervailing duties are imposed, or the amount of a provisional payment or anti-dumping or countervailing right is increased in respect of any dumped or subsidized import, the State is not liable for any amount so required or imposed, or for the amount of any such increase. When, after the said date, such a provisional payment is no longer required or any such anti-dumping or countervailing right is abolished, or where the amount of such provisional payment or any such right is reduced, any such favourable difference shall on demand be paid forthwith by the contractor to the State or the State may deduct such amounts from moneys (if any) which may otherwise be due to the contractor in regard to supplies or services which he delivered or rendered, or is to deliver or render in terms of the contract or any other contract or any other amount which may be due to him

#### **25. Force Majeure**

25.1 Notwithstanding the provisions of GCC Clauses 22 and 23, the supplier shall not be liable for forfeiture of its performance security, damages, or termination for default if and to the extent that his delay in performance or other failure to perform his obligations under the contract is the result of an event of force majeure.

25.2 If a force majeure situation arises, the supplier shall promptly notify the purchaser in writing of such condition and the cause thereof. Unless otherwise directed by the purchaser in writing, the supplier shall continue to perform its obligations under the contract as far as is reasonably practical, and shall seek all reasonable alternative means for performance not prevented by the force majeure event.

#### **26. Termination for insolvency**

26.1 The purchaser may at any time terminate the contract by giving written notice to the supplier if the supplier becomes bankrupt or otherwise insolvent. In this event, termination will be without compensation to the supplier, provided that such termination will not prejudice or affect any right of action or remedy which has accrued or will accrue thereafter to the purchaser.

#### **27. Settlement of Disputes**

27.1 If any dispute or difference of any kind whatsoever arises between the purchaser and the supplier in connection with or arising out of the contract, the parties shall make every effort to resolve amicably such dispute or difference by mutual consultation.

27.2 If, after thirty (30) days, the parties have failed to resolve their dispute or difference by such mutual consultation, then either the purchaser or the supplier may give notice to the other party of his intention to commence with mediation. No mediation in respect of this matter may be commenced unless such notice is given to the other party.

27.3 Should it not be possible to settle a dispute by means of mediation, it may be settled in a South African court of law.

27.4 Mediation proceedings shall be conducted in accordance with the rules of procedure specified in the SCC.

27.5 Notwithstanding any reference to mediation and/or court proceedings herein,

(a) the parties shall continue to perform their respective obligations under the contract unless they otherwise agree; and

(b) the purchaser shall pay the supplier any monies due the supplier.

#### **28. Limitation of liability**

28.1 Except in cases of criminal negligence or wilful misconduct, and in the case of infringement pursuant to

(a) the supplier shall not be liable to the purchaser, whether in contract, tort, or otherwise, for any indirect or consequential loss or damage, loss of use, loss of production, or loss of profits or interest costs, provided that this exclusion shall not apply to any obligation of the supplier to pay penalties and/or damages to the purchaser; and

(b) the aggregate liability of the supplier to the purchaser, whether under the contract, in tort or otherwise, shall not exceed the total contract price, provided that this limitation shall not apply to the cost of repairing or replacing defective equipment.

## **29. Governing language**

29.1 The contract shall be written in English. All correspondence and other documents pertaining to the contract that is exchanged by the parties shall also be written in English.

## **30. Applicable law**

30.1 The contract shall be interpreted in accordance with South African laws, unless otherwise specified in SCC.

**31. Notices** 31.1 Every written acceptance of a bid shall be posted to the supplier concerned by registered or certified mail and any other notice to him shall be posted by ordinary mail to the address furnished in his bid or to the address notified later by him in writing and such posting shall be deemed to be proper service of such notice

31.2 The time mentioned in the contract documents for performing any act after such aforesaid notice has been given, shall be reckoned from the date of posting of such notice.

## **32. Taxes and duties**

32.1 A foreign supplier shall be entirely responsible for all taxes, stamp duties, license fees, and other such levies imposed outside the purchaser's country.

32.2 A local supplier shall be entirely responsible for all taxes, duties, license fees, etc., incurred until delivery of the contracted goods to the purchaser.

32.3 No contract shall be concluded with any bidder whose tax matters are not in order. Prior to the award of a bid the Department must be in possession of a tax clearance certificate, submitted by the bidder. This certificate must be an original issued by the South African Revenue Services.

## **33. National Industrial Participation (NIP) Programme**

33.1 The NIP Programme administered by the Department of Trade and Industry shall be applicable to all contracts that are subject to the NIP obligation.

## **34. Prohibition of Restrictive practices**

34.1 In terms of section 4 (1) (b) (iii) of the Competition Act No. 89 of 1998, as amended, an agreement between, or concerted practice by, firms, or a decision by an association of firms, is prohibited if it is between parties in a horizontal relationship and if a bidder (s) is / are or a contractor(s) was / were involved in collusive bidding (or bid rigging).

34.2 If a bidder(s) or contractor(s), based on reasonable grounds or evidence obtained by the purchaser, has / have engaged in the restrictive practice referred to above, the purchaser may refer the matter to the Competition Commission for investigation and possible imposition of administrative penalties as contemplated in the Competition Act No. 89 of 1998.

34.3 If a bidder(s) or contractor(s), has / have been found guilty by the Competition Commission of the restrictive practice referred to above, the purchaser may, in addition and without prejudice to any other remedy provided for, invalidate the bid(s) for such item(s) offered, and / or terminate the contract in whole or part, and / or restrict the bidder(s) or contractor(s) from conducting business with the public sector for a period not exceeding ten (10) years and / or claim damages from the bidder(s) or contractor(s) concerned.



[www.capenature.co.za](http://www.capenature.co.za)

## **SPECIFICATIONS**

### **BACKGROUND**

The vehicle ferry at Goukamma Nature Reserve comprised of a frame of steel and timber, resting on two steel pontoons made from 3mm thick steel plate with added support. It was used for many years to transport vehicles and staff across the Goukamma river. One vehicle was ferried at a time and then pulled across the river by staff using a cable system.

The ferry was damaged and submerged due to floods and general wear and tear. The pontoons and some parts were recovered. These are currently on the East bank, showing rust damage. The only remaining parts of the top structure are four galvanised ramp lifting towers and ramps, with the rest discarded.

### **REQUIREMENTS**

#### *Pontoons – Repair Existing*

- Load up the pontoons and transport for repairs and upgrades.
- Unbolt and remove top section of pontoons, inspect and identify badly corroded sections.
- Remove badly corroded sections of plate and weld in new sections of plate.
- Wire brush and then sand blast the pontoons inside and out and prepare for painting.
- Re-bolt roof sections with new galvanised bolts to match existing.
- Load and deliver repaired pontoons to Goukamma reserve.

### Pontoon – New Alternative

Tenderers should price Section 3 of the Bill of Quantities to construct new pontoons as opposed to the repair of the existing pontoons. In the summary page only Section 2 total OR Section 3 total should be used to calculate the tender sum (Lower Priced Section).

- Construct new pontoons.
- Bolt cover section onto base section.
- Paint pontoons.
- Deliver to site.

To improve the nett pricing of manufacturing new pontoons as opposed to repairing the existing pontoons, there is an item for the net scrap value of the old pontoons.

### Pontoon Deck and Frame

The pontoon deck and frame need to be rebuilt from scratch apart from the possible reuse of the four galvanized car ramp lifting towers and the four galvanized ramps.

- Fabricate steel frame in accordance with drawings.
- Hot dip galvanise new steel frame.
- Manufacture new corner towers and hot dip galvanise or reuse existing.
- Manufacture new vehicle ramps and galvanise or reuse existing.
- Deliver frame and timber to Goukamma reserve.
- Assemble steel frame and fix it on the repaired or new pontoons.
- Supply and fit stainless-steel pulleys, cables and chain blocks.
- Launch, secure on cable and test pontoon ferry.

### **CIDB GRADING REQUIREMENT**

Bidders must have CIDB contractor grading designation of 3 CE or higher.

## **FUNCTIONALITY**

A bid will be disqualified if it fails to meet the minimum threshold for functionality as per the bid invitation (The minimum threshold will be **70%** of the **100** points awarded for functionality).

Tenderers will be evaluated in terms of information made available in relation to the following categories.

<b>1</b>	<b>Relevant Work Experience and Capability</b>	<b>20</b>
1.1.	<p><u>Previous Contracts in nature reserves and conservation areas</u> Provide a descriptive list of all completed contracts in nature reserves and conservation areas</p> <p><b>Total scoring:</b> <i>5 or more Contracts=10 points; 3-4 Contracts=5 points; 1-2 Contracts=3 points; No Contracts=0 points</i></p>	10
1.2.	<p><u>Letters of Reference</u> Provide favourable letters of reference from architects and/or consultants for completed construction contracts to buildings and developments of a similar in nature or of greater scope to this tender</p> <p><b>Total scoring:</b> <i>5 or more Letters=10 points; 3-4 Letters=5 points; 1-2 Letters =3 points; No Letters =0 points</i></p>	10
<b>2</b>	<b>General Experience and Capability</b>	<b>20</b>
2.1.	<p><u>Current Projects</u> Provide a descriptive list of ANY current projects being undertaken Total scoring:</p> <p><i>5 or more Contracts=5 points; 3-4 Contracts=3 points; 1-2 Contracts=1 point; No Contracts=0 points</i></p>	5
2.2.	<p><u>Previous Projects</u> Provide a descriptive list of all general contracts of similar or greater scope and value completed in the last 5 years.</p> <p><b>Total scoring:</b> <i>5 or more Contracts=5 points; 3-4 Contracts=3 points; 1-2 Contracts=1 point; No Contracts=0 points</i></p>	5
2.3.	<p><u>Letters of Reference</u> Provide favourable letters of reference from architects and/or Clients for alteration contracts of similar or greater scope and value completed in the last 5 years.</p> <p><b>Total scoring:</b> <i>5 or more Letters=10 points; 3-4 Letters=5 points; 1-2 Letters =3 points; No Letters =0 points</i></p>	10
<b>3</b>	<b>Contract Management Capability</b>	<b>10</b>
3.1.	<p><u>Contract Management Personnel - General</u> Provide CV and details of the company in-house capacity for contract administration by giving the details of at least one personnel member qualified in the field of construction management</p> <p><b>Scoring – add up the following:</b> <i>Formal tertiary construction management qualification=5 points; More than 5 years fulltime contract management experience=5 points; Less than 5 years fulltime contract management experience=3 points.</i></p>	10

<b>4</b>	<b>Resources</b>	<b>30</b>
4.1.	<p><u>Project organogram</u> Provide a detailed organogram and CV's of the leadership and management structure you intend to mobilize on a substantially full-time basis on this contract (INCLUDING architects, engineers, surveyors)</p> <p><b>Scoring – add up the following:</b> <i>Personnel experience details=5 points; Employer's adequacy rating of organogram=3 points; Personnel tertiary qualification details=2 points</i></p>	10
4.2.	<p><u>Company infrastructure</u></p> <ul style="list-style-type: none"> <li>Provide a detailed list of key plant and manpower capacity available locally of your company with specific reference to the operational needs of this project from the point of view of construction</li> </ul> <p><b>Scoring – add up the following:</b> <i>Own plant resources=5 points; Hired plant resources=3 points Own manpower resources=5 points; Subcontracted manpower resource =3 points</i></p>	10
4.3.	<p><u>Project Construction Management Personnel</u></p> <ul style="list-style-type: none"> <li>Provide CV of the Construction Manager for contract administration, who will be employed on this contract</li> </ul> <p><b>Scoring – add up the following:</b> <i>5 or more contract experience=5 points; Less than 5 contract experience= 3 points.</i></p>	5
4.4.	<p><u>Project full time key personnel – Support role</u></p> <ul style="list-style-type: none"> <li>Provide CV of the key personnel to be employed on a <b>substantially full time</b> on this project.</li> </ul> <p><b>Scoring – add up the following:</b> <i>5 or more general contract experience=5 points; Less than 5 general contract experience= 3 points.</i></p>	5
<b>5</b>	<b>Approach</b>	<b>20</b>
5.1.	<p><u>Construction programme</u></p> <ul style="list-style-type: none"> <li>The attention of the tenderers is drawn to the dates for completion of construction documentation in the document.</li> <li>Provide an indicative construction programme including the dates for various provisional sums and completing all finishes.</li> </ul> <p><b>Scoring – add up the following:</b> <i>Construction programme provided =5 points; No construction programme provided = 0 points.</i></p>	5
5.2.	<p><u>Health &amp; Safety Procedures</u></p> <ul style="list-style-type: none"> <li>Tenderers are to submit details of their Health and Safety procedures.</li> </ul> <p><b>Scoring – add up the following:</b> <i>Health &amp; safety procedures provided =5 points; No health &amp; safety procedures provided = 0 points.</i></p>	5
5.3.	<p><u>Environmental Management Plan</u></p> <ul style="list-style-type: none"> <li>Tenderers are to submit details of their Environmental Management Plan.</li> </ul> <p><b>Scoring – add up the following:</b> <i>Environmental Management Plan provided =10 points; No Environmental Management Plan provided = 0 points.</i></p>	10
	<b>TOTAL FUNCTIONALITY SCORE</b>	<b>100</b>

## **COMPULSORY SITE BRIEFING**

The compulsory site briefing session will take place at Goukamma Nature Reserve on 28 May 2025 at 10:00 AM.

## **DIRECTIONS TO THE RESERVE**

Goukamma Nature Reserve is situated between Sedgefield and Knysna 5 Kilometres along the Buffalo Bay Road.

GPS: 34°4'6.73"S 22°56'52.29"E

## **SUBMISSION OF BID**

Bids either need to be submitted electronically to [tenders@capenature.co.za](mailto:tenders@capenature.co.za) or physically delivered to CapeNature Head Office by 11:00 AM on Wednesday 18 June 2025.

### CapeNature Head Office Address:

CapeNature Head Office  
3<sup>rd</sup> Floor  
PGWC Shared Services Centre  
Cnr Bosduif and Volstruis Streets  
Bridgetown  
7764

## **CONTACT PERSON**

For any technical information or enquiries please contact Barend Le Roux or Mzwandile Xipu:

E-mail: [bleroux@capennature.co.za](mailto:bleroux@capennature.co.za) , [mxipu@capennature.co.za](mailto:mxipu@capennature.co.za)

Telephone: 087 087 3061 , 087 087 2177

For any bidding procedure enquiries please contact Imran Brey:

E-mail: [ibrey@capennature.co.za](mailto:ibrey@capennature.co.za)

Telephone: 087 087 4103

For any engineering queries please contact Rein Hofmeyr:

E-mail: [hofmeyr@hofmeyrassociates.co.za](mailto:hofmeyr@hofmeyrassociates.co.za)

Telephone: 082 336 8895

## **REJECTION OF QUOTES/PROPOSALS**

Any effort by a bidder to influence the bid evaluation, comparisons, or award decisions in any manner, may result in rejection of the bid. CapeNature shall reject a bid if the bidder has committed a proven corrupt or fraudulent act in competing for a particular contract. CapeNature may disregard any bid if the bidder or any of its subcontractors:

- Is not tax compliant.
- Have abused the Supply Chain Management (SCM) system of a department or any other government department, agency, or entity.
- Have committed proven fraud or any other improper conduct in relation to such system.
- Have failed to perform on any previous contract.
- Supplied incorrect information in the bid documentation.
- Not fully registered on the Central Supplier Database (CSD).
- Did not submit a valid Declaration of Interest.

## **DISCLAIMER**

Details of the award will be published (on the e-tender portal/ other media) by CapeNature under National Treasury Instruction No. 1 of 2015/2016

1 JONKER STREET, INDUSTRIAL  
 AREA, KNYSNA, 6570  
[hofmeyr@hofmeyrassociates.co.za](mailto:hofmeyr@hofmeyrassociates.co.za)

P.O BOX 1009  
 KNYSNA, 6570  
 TEL (044) 382 0996

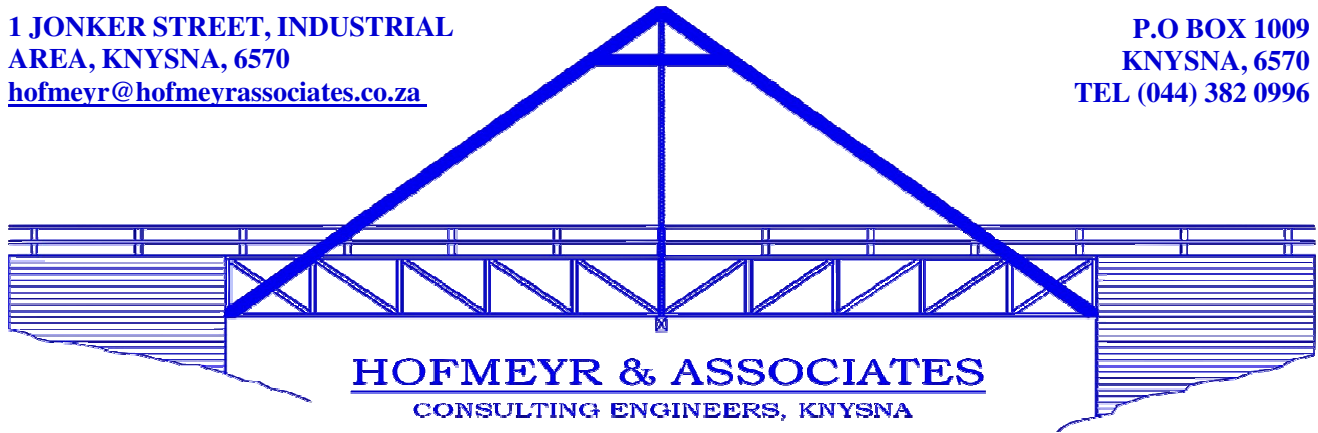

**SUMMARY OF BILL OF QUANTITIES**

Section	Description	Amount
<b>Section 1</b>	Preliminary & General	R 0.00
<b>Section 2</b>	Pontoons	R 0.00
<b>Section 3</b>	Pontoons New Alternative	R 0.00
<b>Section 4</b>	Top Structure	R 10 000.00
<b>Sub-total</b>		<b>R 0.00</b>
	Allow 10% contingencies to be used in whole or in part where Instructed by the Engineer	R 0.00
<b>Sub-total</b>		<b>R 0.00</b>
	15% Vat	R 0.00
<b>TOTAL TENDER SUM</b>		<b>R 0.00</b>

**NOTE:** ENTER THE LOWER TOTAL OF EITHER SECTION 2 OR 3 INTO SUMMARY

**Total Tender Sum in Words:**

**Contract Period:** .....

**Signed:** .....

**Date:** .....

**Name:** .....

**Position:** .....

**Tenderer:** .....

GOUKAMMA NATURE RESERVE FERRY  
16 MAY 2025

<b>SECTION 1: P &amp; G</b>						
<b>ITEM</b>	<b>PAYMENT REFERS</b>	<b>DESCRIPTION</b>	<b>UNIT</b>	<b>BILLED QTY</b>	<b>RATE</b>	<b>AMOUNT R</b>
<b>1</b>		<b>Preliminary &amp; General Costs</b>				
1.1		P&G Costs	Sum	1		
1.2		Costs to comply with Health & Safety requirements	Sum	1		
1.3		Costs to comply with enviromental management plan		1		
<b>TOTAL - CARRIED TO SUMMARY</b>						<b>0.00</b>
<b>SECTION 2: PONTOONS</b>						
<b>ITEM</b>	<b>PAYMENT REFERS</b>	<b>DESCRIPTION</b>	<b>UNIT</b>	<b>BILLED QTY</b>	<b>RATE</b>	<b>AMOUNT R</b>
<b>2</b>		<b>Pontoons - Repair Existing</b>				
2.1		Load & Cart Pontoons to Workshop	No.	2		0.00
2.2		Unload, Wash Down & Unbolt Roof section from Pontoons	No.	2		0.00
2.3		Cut Out, Supply, Bend & Weld in place new sections of 3mm plate	m <sup>2</sup>	10		0.00
2.4		Weld new plate to old	m	60		0.00
2.5		Make up new manhole covers using 3mm plate 750mm x 350mm with 40mm down stand around outside	No	4		0.00
2.6		Sand Blast inside & outside of Pontoons & prepare for painting	m <sup>2</sup>	220		0.00
2.7		Supply & apply 2 coats Jotacote Universal N10 Aluminium (each coat 220m <sup>2</sup> ) to pontoons inside and outside <b>* Note:</b> Before every full coat, a stripe coate must be applied by brush on all edges, corners, welding seams & other difficult to reach areas in order to build up the dry film thickness in these areas.	m <sup>2</sup>	220		0.00
2.8		Supply & apply 1 coat of Pengard Top coat to outside of pontoon below water line <b>* Note:</b> Before every full coat, a stripe coate must be applied by brush on all edges, corners, welding seams & other difficult to reach areas in order to build up the dry film thickness in these areas.	m <sup>2</sup>	50		0.00
2.9		Supply & apply 1 coat of Hardtop Flexi to outside of pontoon above water line <b>* Note:</b> Before every full coat, a stripe coate must be applied by brush on all edges, corners, welding seams & other difficult to reach areas in order to build up the dry film thickness in these areas.	m <sup>2</sup>	60		0.00
2.10		Re-Bolt Roof Sections	No.	2		0.00
2.11		10mm diameter galvanised bolts 25mm long	No.	170		0.00
2.12		Load & Cart Pontoons to Goukamma Nature Reserve & Unload	No.	2		0.00
2.13		Touch Up Paint System as Required	Sum	1		0.00



GOUKAMMA NATURE RESERVE FERRY  
16 MAY 2025

<b>SECTION 3: PONTOONS NEW ALTERNATIVE</b>						
<b>ITEM</b>	<b>PAYMENT REFERS</b>	<b>DESCRIPTION</b>	<b>UNIT</b>	<b>BILLED QTY</b>	<b>RATE</b>	<b>AMOUNT R</b>
<b>3</b>		<b>PONTOONS - NEW ALTERNATIVE</b>				
3.1		Make up new pontoons cut, bend & weld 3mm thick 3CR12 plate	m <sup>2</sup>	115		0.00
3.2		50mm x 50mm x 5mm angle 3CR12 cut & weld or bolt	m	60		0.00
3.3		Cut & weld in place 5mm thick 3CR12 gussets	m <sup>2</sup>	8		0.00
3.4		10mm diameter x 25mm long A4 Stainless steel bolts	No	190		0.00
3.5		Supply & Apply 1 coat of Pengard Top coat (each coat 220m <sup>2</sup> ) to pontoons inside and outside <b>* Note:</b> Before every full coat, a stripe coate must be applied by brush on all edges, corners, welding seams & other difficult to reach areas in order to build up the dry film thickness in these areas.	m <sup>2</sup>	220		0.00
3.6		Supply & apply 1 coat of Pengard Top coat to outside of pontoon below water line <b>* Note:</b> Before every full coat, a stripe coate must be applied by brush on all edges, corners, welding seams & other difficult to reach areas in order to build up the dry film thickness in these areas.	m <sup>2</sup>	50		0.00
3.7		Supply & apply 1 coat of Hardtop Flexi to outside of pontoon above water line <b>* Note:</b> Before every full coat, a stripe coate must be applied by brush on all edges, corners, welding seams & other difficult to reach areas in order to build up the dry film thickness in these areas.	m <sup>2</sup>	60		0.00
3.8		Assemble cover section onto lower section of pontoon		1		0.00
3.9		Deliver to site		1		0.00
<b>TOTAL - CARRIED TO SUMMARY</b>						<b>0.00</b>
<b>SECTION 4 : TOP STRUCTURE</b>						
<b>ITEM</b>	<b>PAYMENT REFERS</b>	<b>DESCRIPTION</b>	<b>UNIT</b>	<b>BILLED QTY</b>	<b>RATE</b>	<b>AMOUNT R</b>
<b>4</b>		<b>Top Structure</b>				
4.1		Manufacture Steel Frame in 2 sections as per DWG No. 23/01-001 & 23/01/002 Consisting of:				
4.1.1		100mm x 50mm SA Parallel Flange Channel	m	70		0.00
4.1.2		50mm x 50mm x 5mm Angle Iron	m	20		0.00
4.1.3		50mm x 5mm Flat Bar	m	13		0.00
4.2		Galvanize steel frame on 2 sections	Sum	1		0.00
4.3		Manufacture 4 Corner Towers as per drawing No. 23/01/002 Consisting of:				

GOUKAMMA NATURE RESERVE FERRY  
16 MAY 2025

4.3.1	100mm x 50mm SA Parallel Flange Channel	m	10		0.00
4.3.2	50mm x 50mm x 5mm Angle Iron		26		0.00
4.3.3	50mm x 5mm Flat Bar		4		0.00
4.4	Hot Dip Galvanize Corner Towers	No.	4		0.00
4.5	Manufacture Vehicle Ramps & Brackets as per drawing No. 23/01/002 Consisting of:				
4.5.1	76mm x 153mm x 18.5mm Tee Section	m	8		0.00
4.5.2	70mm x 70mm x 6 Angle Iron	m	22		0.00
4.5.3	20mm x 100mm Flat Bat	m	3		0.00
4.5.4	10mm x 200 Flat Bar	m	2		0.00
4.5.5	10mm Plate	m	0.5		0.00
4.5.6	40mm diameter Rod	m	3		0.00
4.5.7	48mm diameter x 3 Pipe	m	1.5		0.00
4.6	Hot Dip Galvanize Ramps & Brackets	No.	4		0.00
4.7	Deliver Frame & Accessories to site	Sum	1		0.00
4.8	Assemble on site & place on pontoons	Sum	1		0.00
4.9	Supply & Bolt in place 76mm x 228mm H5 Treated SA Pine	m	150		0.00
4.10	10mm diameter bolts 100mm long, hot dip galvanised	No.	370		0.00
4.11	Clean up & Reuse existing corner towers as opposed to making up new	No.	4		RATE ONLY
4.12	Clean up & Reuse existing Ramps as opposed to making up new Allow for new pins	No.	4		RATE ONLY
4.13	Supply Stainless steel pulleys, cables, chain hoist as directed	Prov Sum			10 000.00
4.14	Contractors mark up on 4.13	%			
<b>TOTAL - CARRIED TO SUMMARY</b>					<b>R 10 000.00</b>























































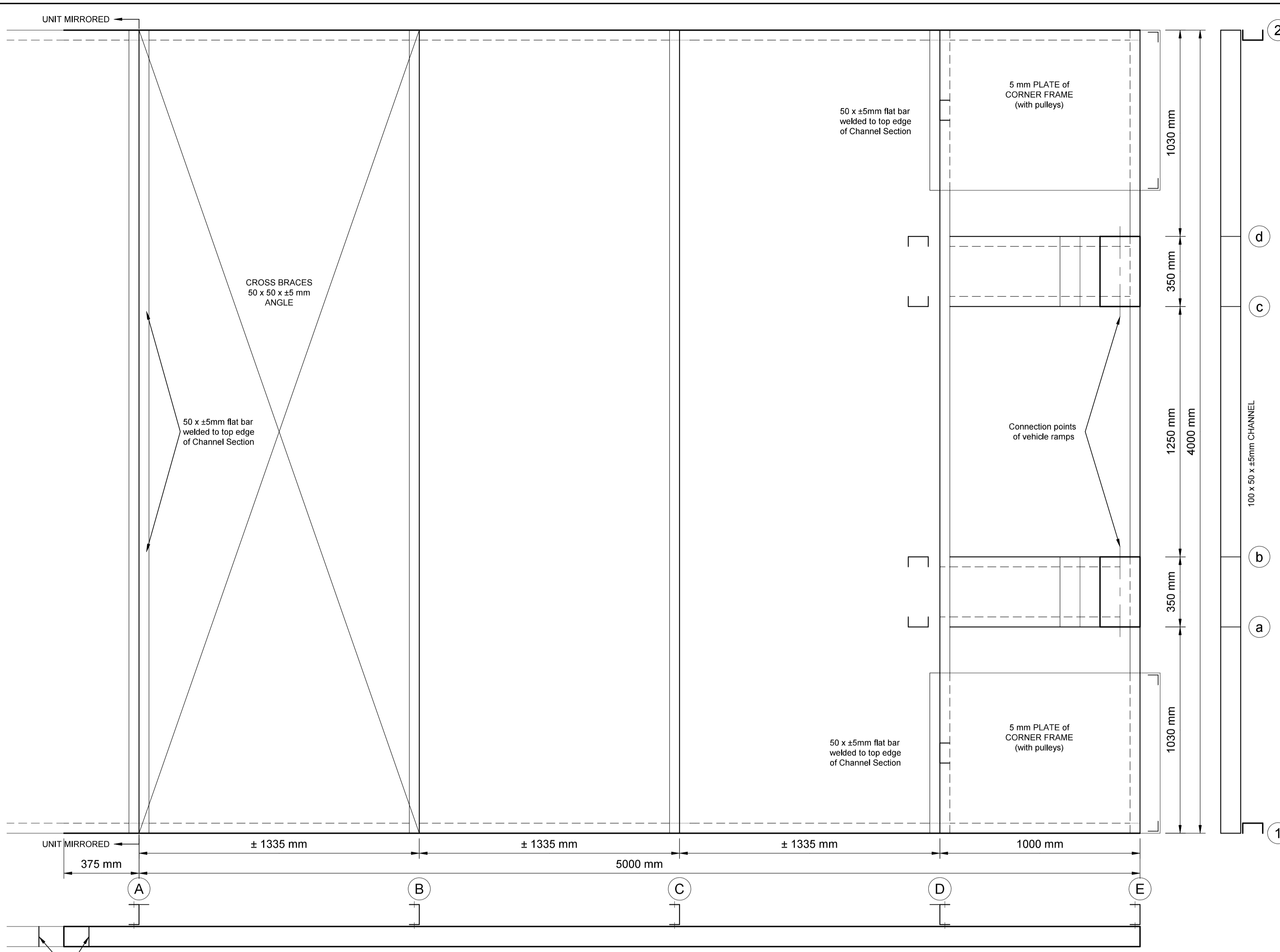

PLAN VIEW - STEEL FRAME STRUCTURE NTS

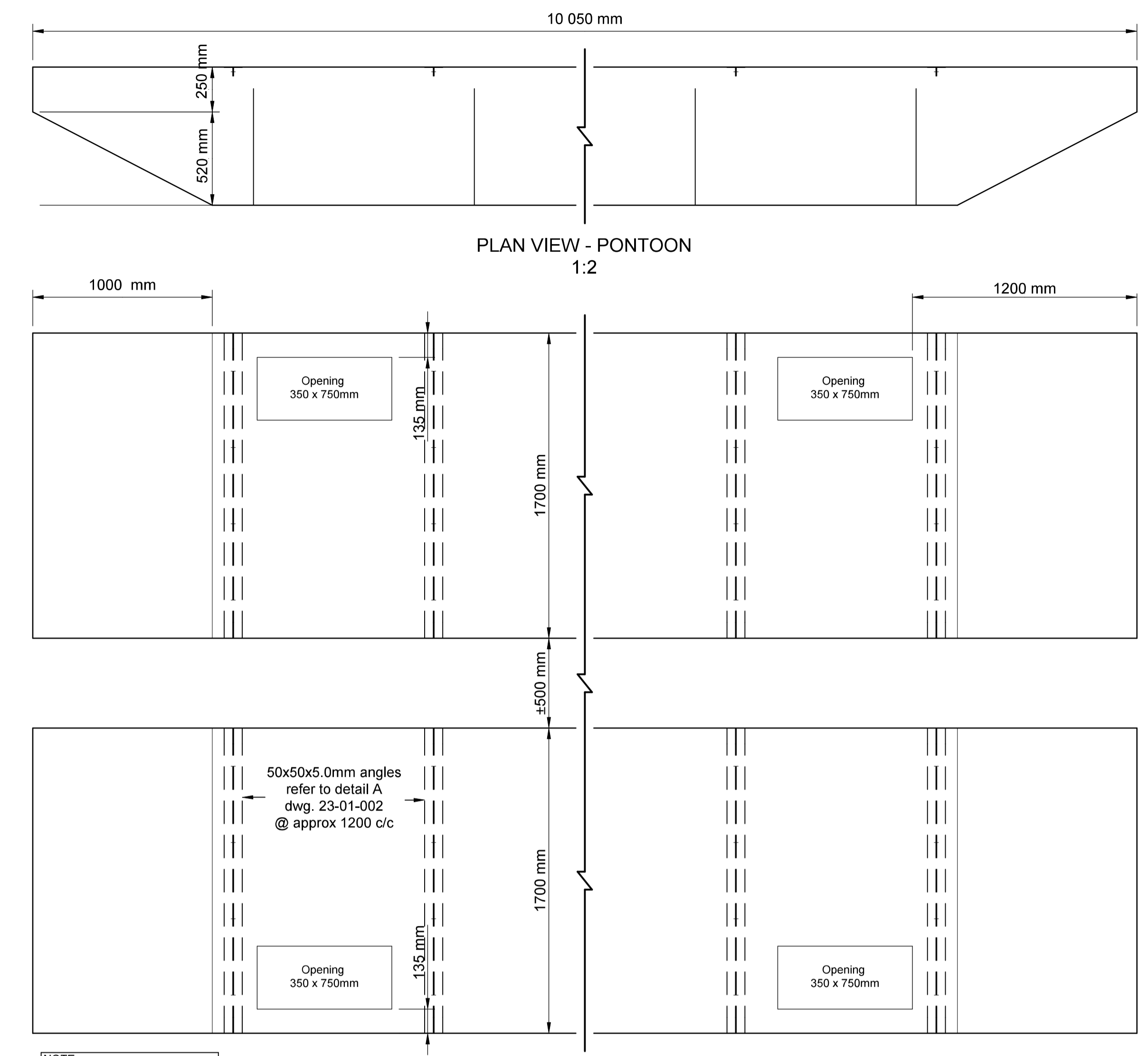

PLAN VIEW - PONTOON 1:2

TOP VIEW - PONTOON 1:2

NOTE: The steel frame structure is NOT bolted onto the pontoons

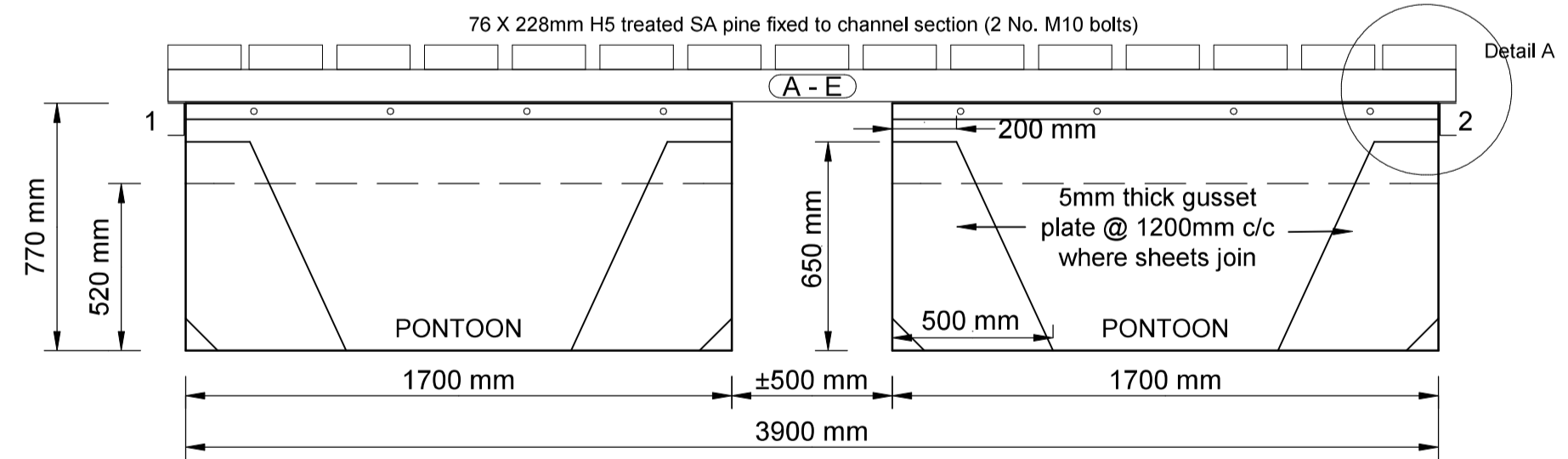
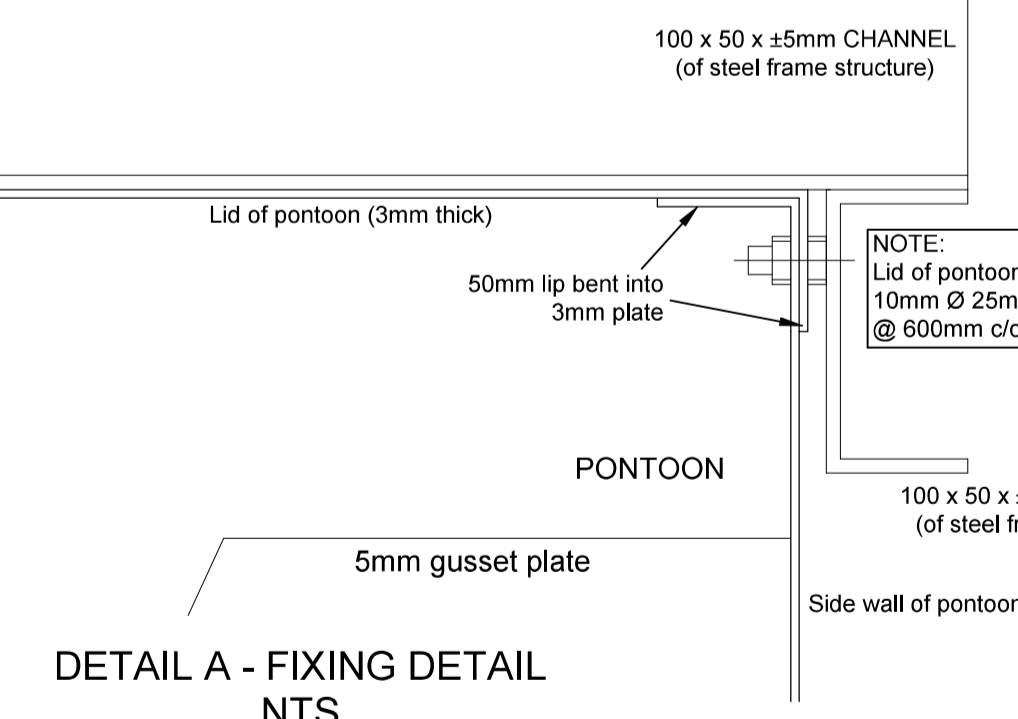
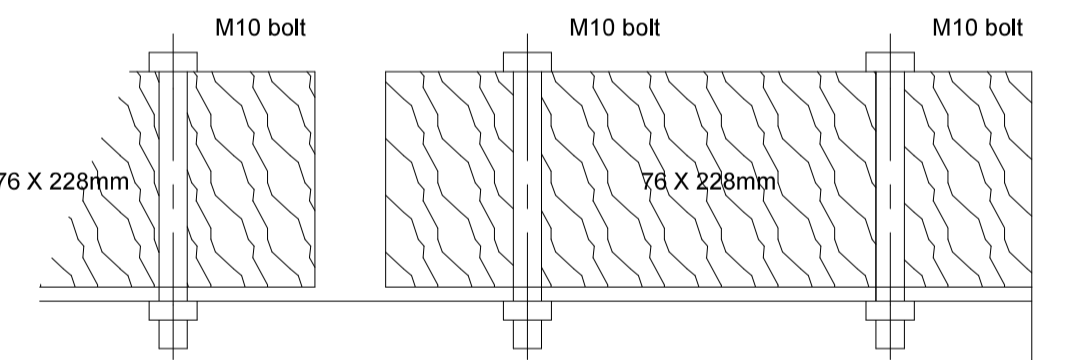

FRONT VIEW - PONTOON 1:2

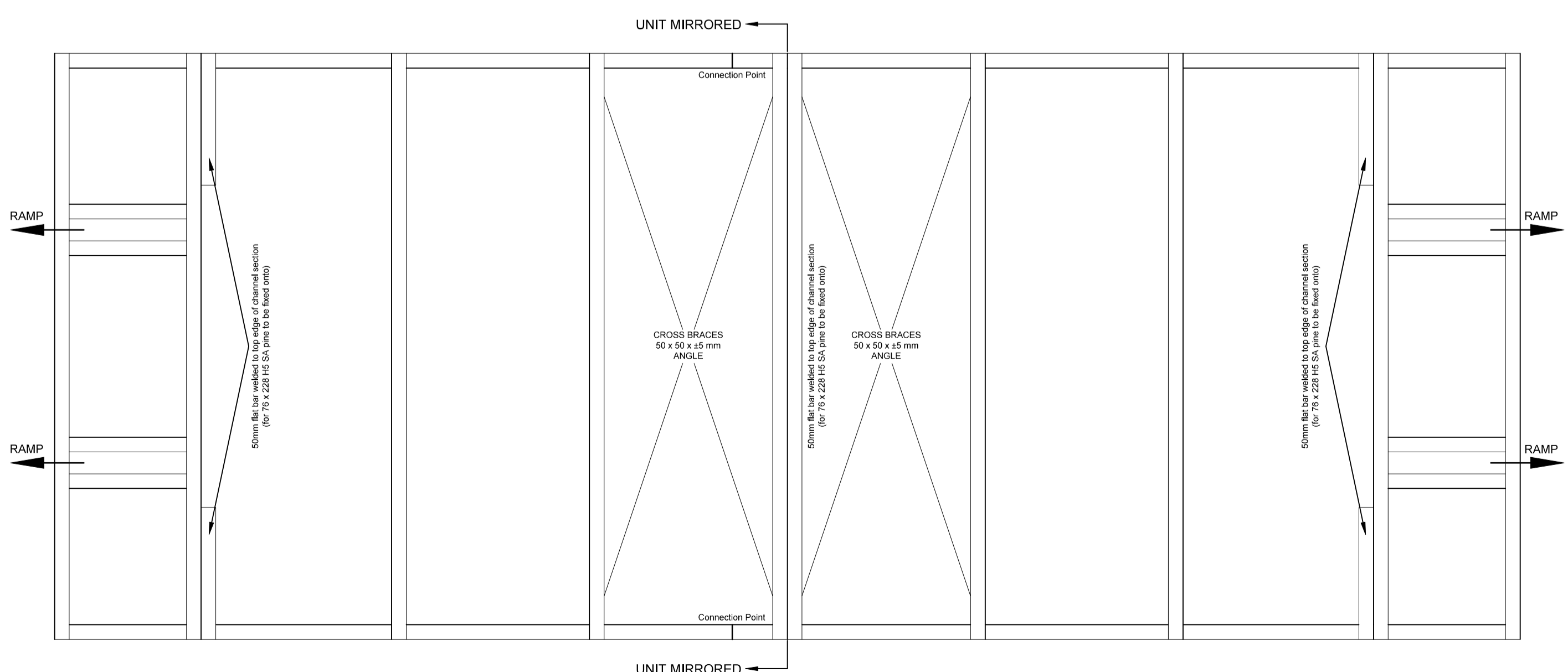

REFERENCE DRAWING: 23-01-002

				CLIENT	CAPE NATURE			
				PROJECT	CAPE NATURE FERRY - GOUKAMMA RESERVE, KNYSNA			
				TITLE	STEEL & TIMBER SUPER STRUCTURE - FERRY			
					SCALE	PAPER SIZE	DRAWING NO	
					AS SHOWN	A1	23/01 - 001	
				DATE	DESIGNED	R. HOFMEYR		
				NO	DRAWN	J. VICTOR		
				REVISIONS DETAILS		CHECKED	R. HOFMEYR	0

**HOFMEYR & ASSOCIATES**  
 1 JONKER STREET  
 KNYSNA INDUSTRIAL  
 P.O. BOX 1009  
 KNYSNA, 6570  
 tel: 044-382 0996  
 fax: 044-382 2467  
 hofmeyr@hofmeyr  
 associates.co.za

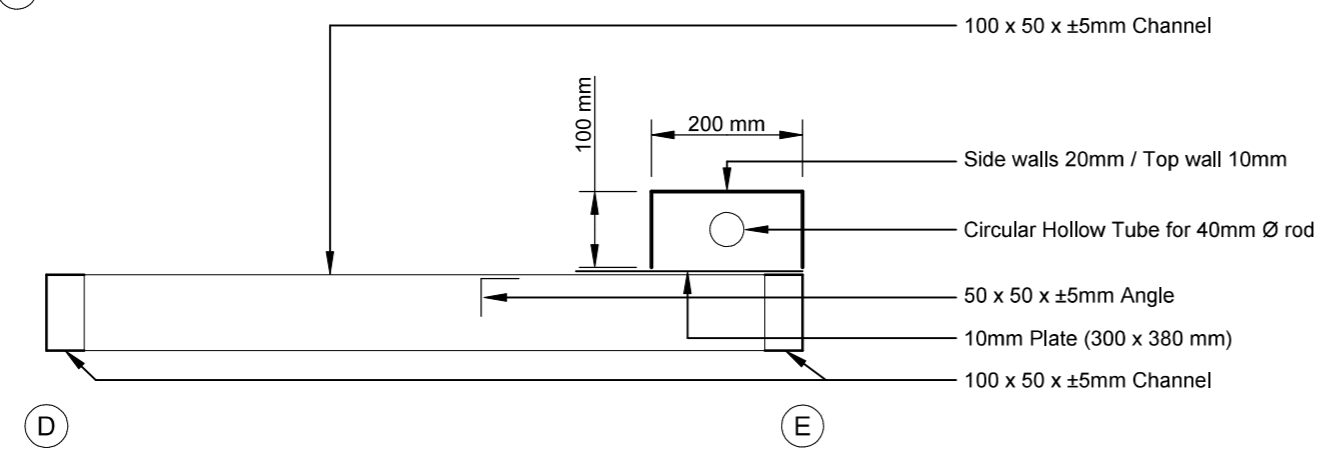
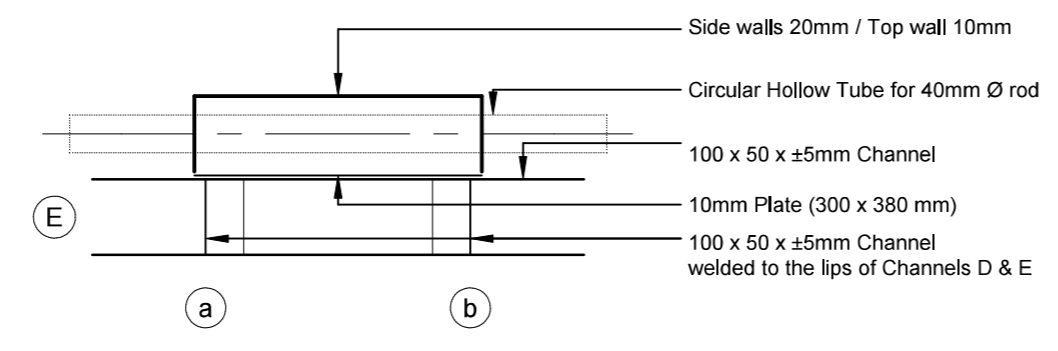
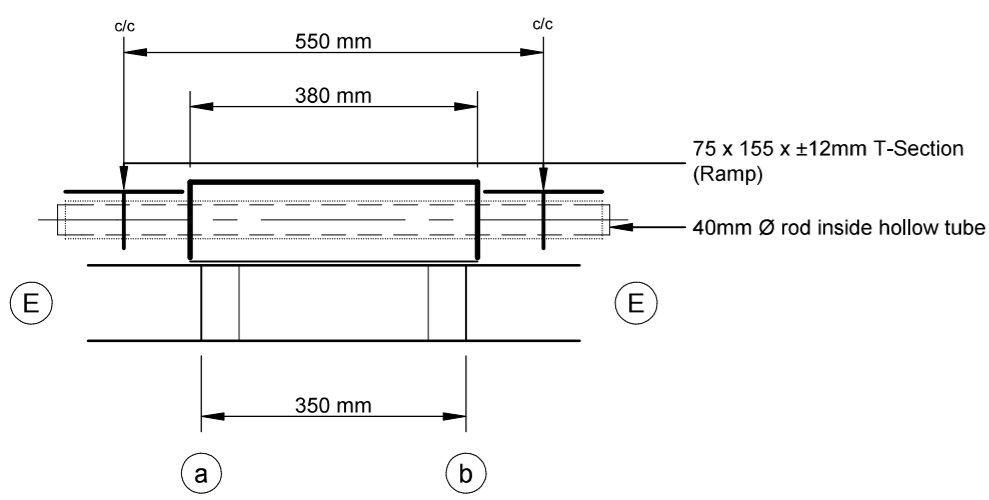

CONNECTION DETAIL - RAMP TO STRUCTURE  
SCALE 1:1

GENERAL NOTES:  
1.

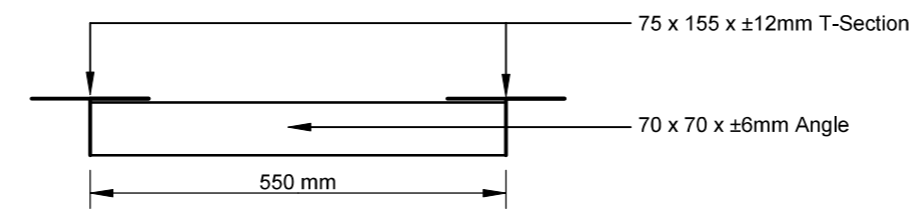
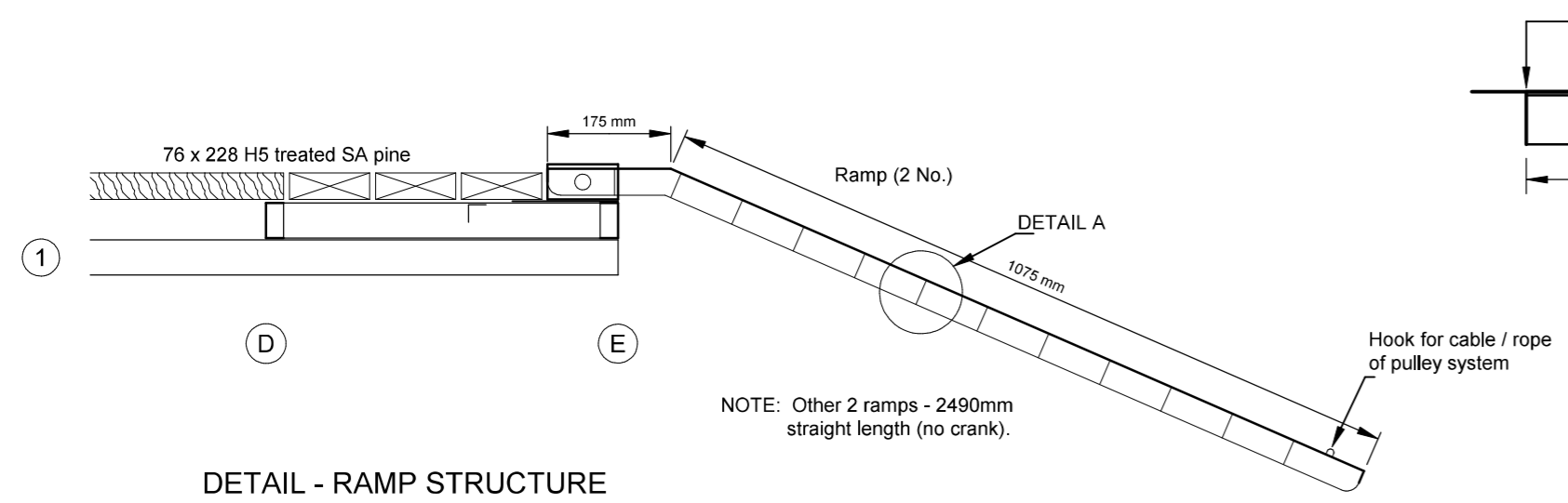
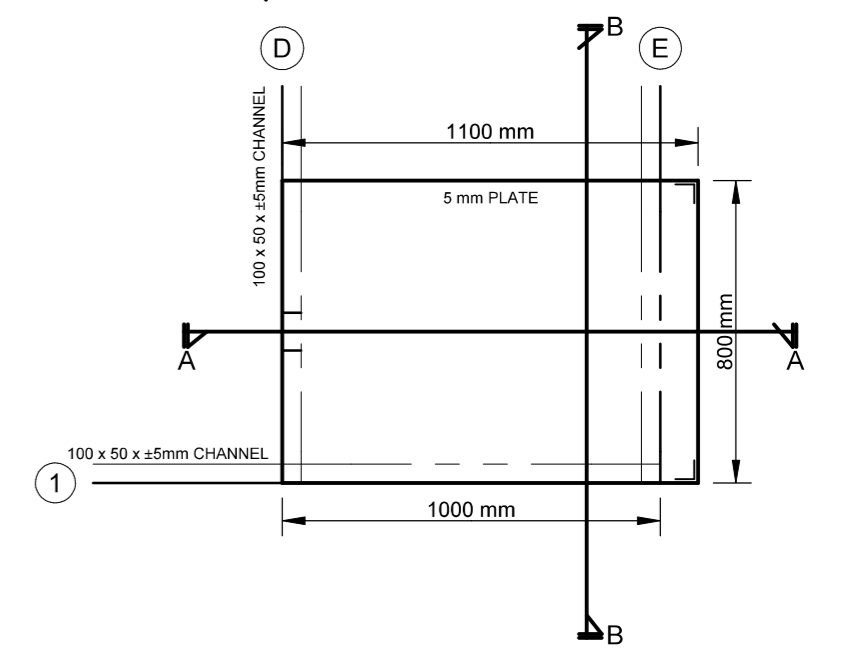

DETAIL A  
SCALE 1:1

DETAIL - RAMP STRUCTURE  
SCALE 1:2

NOTE: Other 2 ramps - 2490mm straight length (no crank).

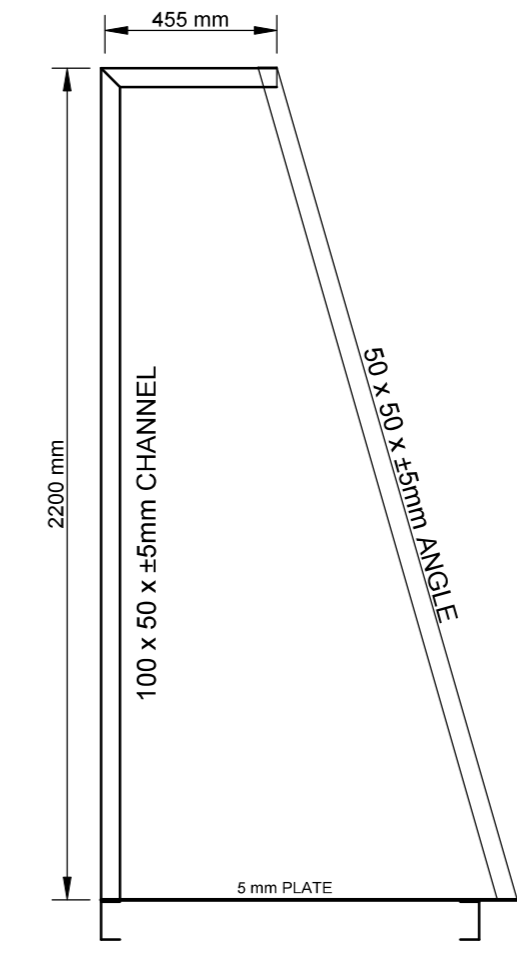

SECTION A-A

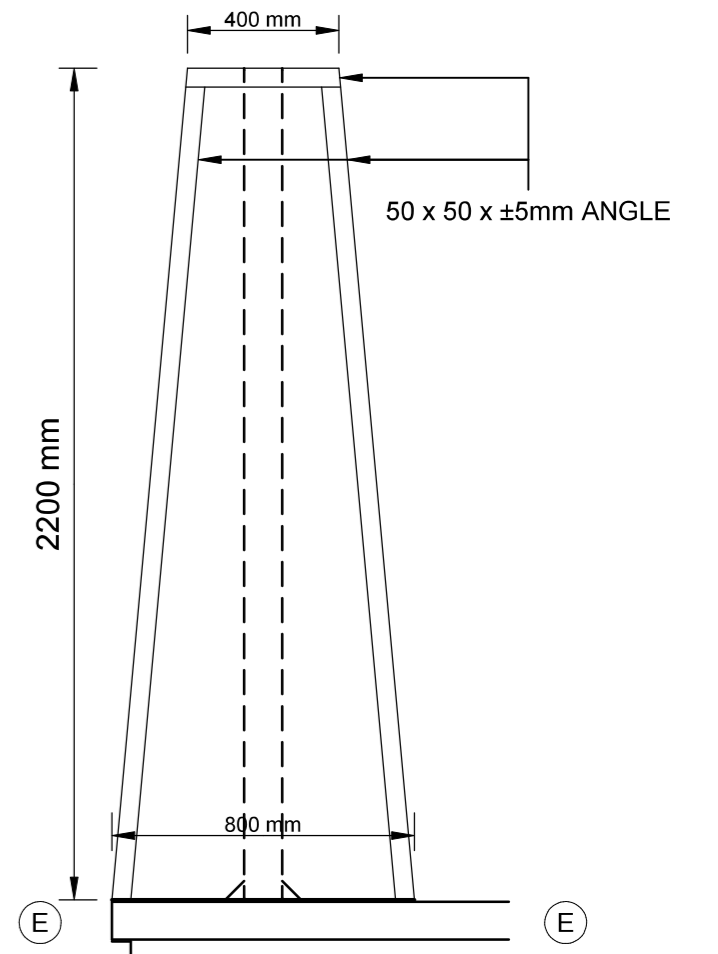

SECTION B-B

DETAIL: VERTICAL CORNER FRAMES (4 No.)  
SCALE 1:2

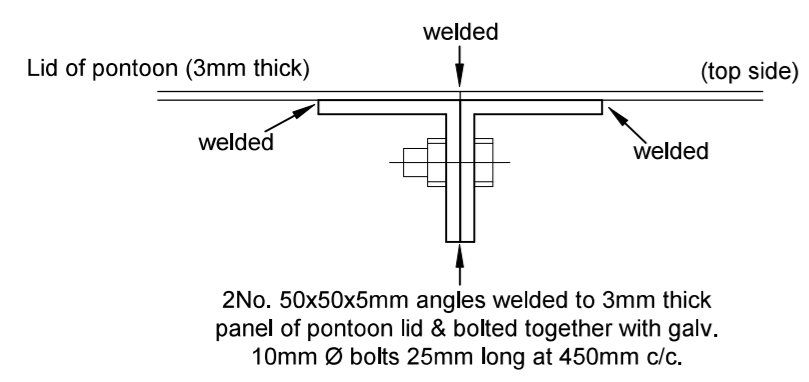

DETAIL B - FIXING DETAIL OF PONTOON LID PANELS  
NTS

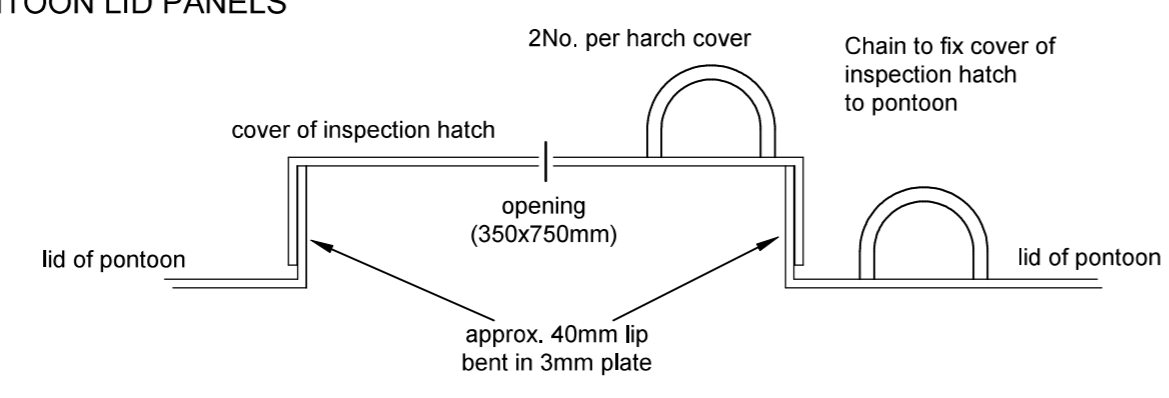

DETAIL - COVER OF INSPECTION HATCH (350X750mm)  
NTS

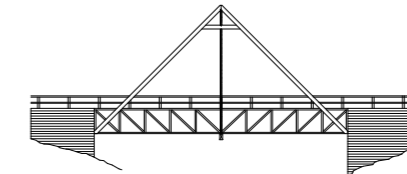
CLIENT				CAPE NATURE			
PROJECT				CAPE NATURE FERRY - GOUKAMMA RESERVE, KNYSNA			
TITLE				STEEL & TIMBER SUPER STRUCTURE - FERRY			
		SCALE	PAPER SIZE	DRAWING NO		23/01 - 002	
		AS SHOWN	A2				
DATE		DESIGNED	DRAWN		CHECKED		REVISIONS
24/03/2025		R. HOFMEYR	J. VICTOR		R. HOFMEYR		0 1
00 FOR TENDER PURPOSES		03/03/2025	JDV				
NO DESCRIPTION		DATE	SIGNED				
REVISIONS DETAILS							

**HOFMEYR & ASSOCIATES**  
1 JONKER STREET  
KNYSNA INDUSTRIAL  
P.O. BOX 1009  
KNYSNA, 6570  
tel: 044-382 0996  
fax: 044-382 2467  
hofmeyr@hofmeyr  
associates.co.za